

# THE MADISON A

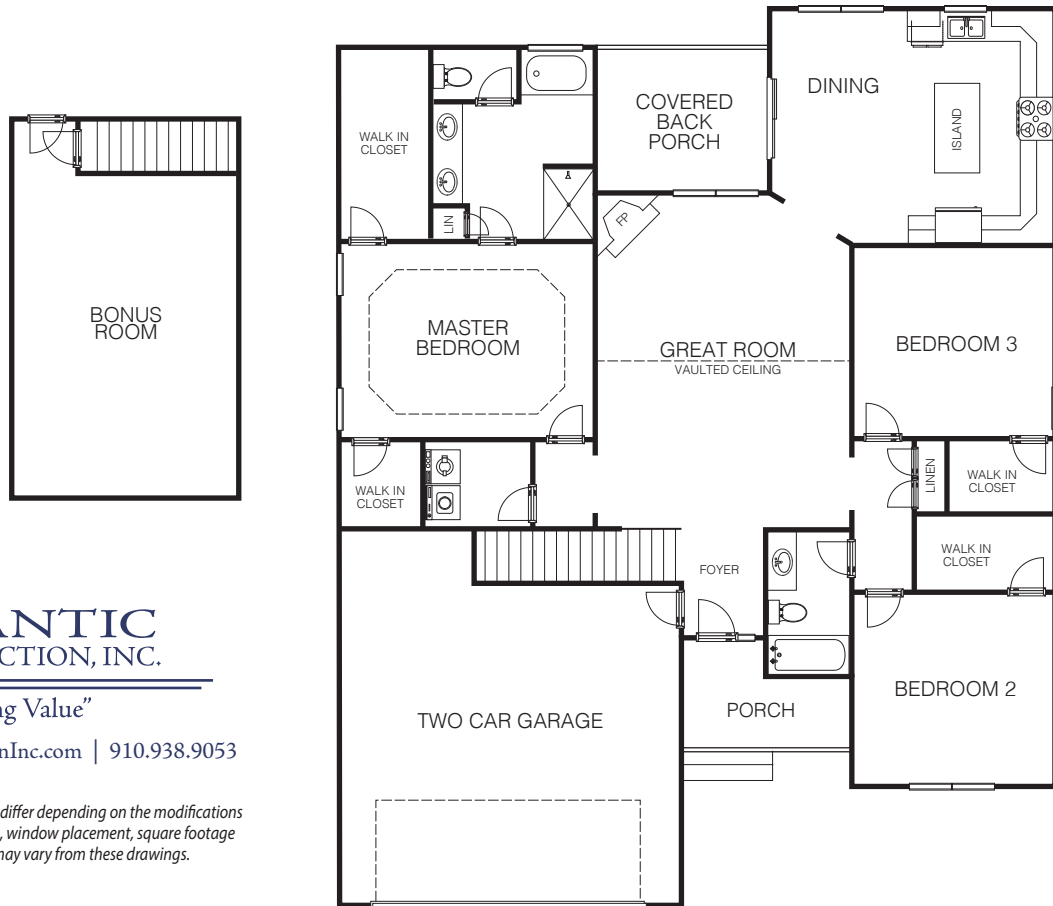

**ATLANTIC  
CONSTRUCTION, INC.**

"Building Value"

[www.AtlanticConstructionInc.com](http://www.AtlanticConstructionInc.com) | 910.938.9053

*Artist's representation only. Plans may differ depending on the modifications performed by the builder. Room sizes, window placement, square footage totals, and other dimensions may vary from these drawings.*



# A14W

# Madison

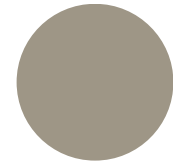
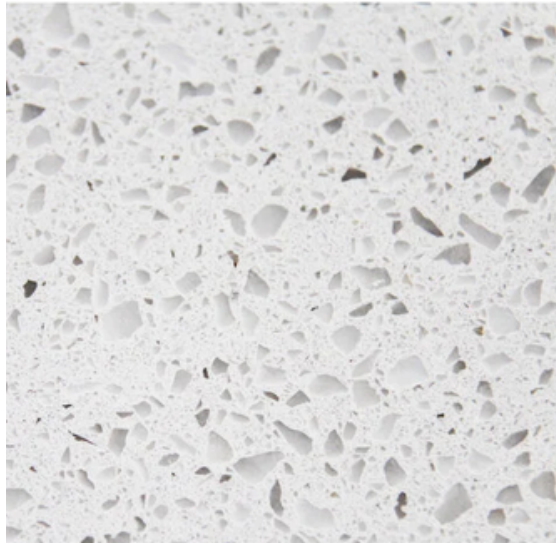
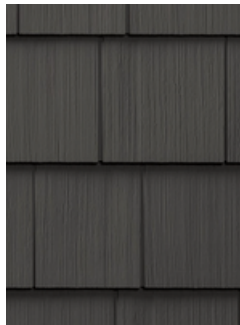
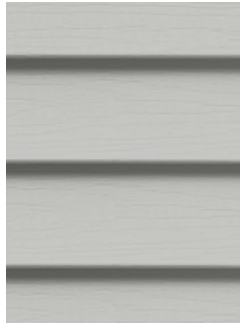

ATLANTIC  
CONSTRUCTION, INC  
"Building Value"

RL  
RAYNOR, LACORTE  
& ASSOCIATES

A14W

Madison

## Exterior

<b>Siding:</b>	Sterling
<b>Cedar Shake:</b>	Slate
<b>Board and Batten:</b>	Slate
<b>Shutter Color:</b>	Black
<b>Shutter Style:</b>	Raised Panel
<b>Shingles:</b>	Black

## Interior

<b>Cabinets:</b>	Mist (Light Gray)
<b>Quartz Countertops:</b>	Frost White
<b>LVP Flooring:</b>	Turntable
<b>Carpet:</b>	Greige
<b>Interior Paint:</b>	City Loft



**ONSLow COUNTY**  
 234 NW Corridor Boulevard Jacksonville, NC  
 28540 (910) 455-3661

# Permit

Permit NO. **RBLD-2026-00180**

Permit Type: **Residential Building**

Work Classification: **Residential Single Family Dwelling**

Permit Status: **Issued**

Issue Date: **02/26/2026**

**Expiration: 08/25/2026**

**Location Address**

**Parcel Number**

**121 WOODFORD DRIVE, JACKSONVILLE, NC 28540**

**54D-75**

**Contacts**

**ATLANTIC CONSTRUCTION INC** **Applicant**  
 7 E DORIS AVE, JACKSONVILLE, NC 28540  
 (910)938-9053 CHASS@ATLANTICCONSTRUCTIONINC.COM

**BUCEK'S PLUMBING COMPANY, INC.** **.Plumbing Contractor**  
 2570 WILMINGTON HWY, JACKSONVILLE, NC 28540  
 (910)347-6607 OFFICE@BUCEKSPLUMBING.COM

**ATLANTIC CONSTRUCTION, INC.** **General Contractor**  
 7 E DORIS AVE, JACKSONVILLE, NC 28540  
 (910)938-9053 CHASS@ATLANTICCONSTRUCTIONINC.COM

**WILLIAMS BROTHERS ELECTRIC INC** **Electrical Contractor**  
 768 GRANTS CREEK RD, JACKSONVILLE, NC 28546  
 (910)389-7890 WILLIAMSBRoelec@YAHOO.COM

**KENNEDY'S HEATING & AIR** **Mechanical Contractor**  
 CONDITIONING, LLC  
 488 FOWLER MANNING ROAD, RICHLANDS, NC 28574  
 (910)750-2648 KENNEDYSHEATINGANDAIR@GMAIL.COM

**Description:** Construct SFD

**Valuation:**     \$90,000.00    

**Total Sq Feet:**     2,810.00    

**Inspection Requests:**

Building (910) 455-3661 or  
 Environmental Health (910) 938-5851



**ONSLow COUNTY**  
 234 NW Corridor Boulevard Jacksonville, NC  
 28540 (910) 455-3661

# Permit

Permit NO. **RBLD-2026-00180**

Permit Type: **Residential Building**

Work Classification: **Residential Single Family Dwelling**

Permit Status: **Issued**

Issue Date: **02/26/2026**

**Expiration: 08/25/2026**

Fees	Amount
Electrical - Temporary Power	\$50.00
GC-Home Owners Recovery Fund - Admin	\$1.00
GC-Home Owners Recovery Fund - Pay	\$9.00
Residential Building - Single Family Dwelling	\$1,183.50
Zoning - Zoning Permit	\$50.00
<b>Total:</b>	<b>\$1,293.50</b>

Payments	Amt Paid
<b>Total Fees</b>	<b>\$1,293.50</b>
Check # *****9684	\$1,293.50
<b>Amount Due:</b>	<b>\$0.00</b>

Available Inspections:	
Inspection Type	IVR
Setback Inspection	53
Footing	100
Foundation Inspection	105
Plumbing Under Slab Inspection	405
Slab and Elevation Inspection	110
Saw Service Inspection	200
Rough-In Electrical Inspection	455
Rough-In Framing Inspection	465
Rough-In Gas and Fuel Inspection	490
Rough-In Mechanical Inspection	475
Rough-In Plumbing Inspection	480
Underground Wastewater Inspection	220
Underground Water Supply Inspection	225
Insulation Inspection	233
Temporary Power Inspection	190
Partial Framing	
Residential - Compliance Zoning Inspection	20202
Compliance Building Inspection	520
Compliance Gas and Fuel Inspection	540
Compliance Mechanical Inspection	545
Compliance Plumbing Inspection	550
Compliance Electrical Inspection	525

Permission to Enter Land: I certify that I am authorized to grant, and do in fact, grant permission to Onslow County Planning and Development employees and their agents, to enter on the property noted on the Onslow County permit for the purpose of inspections.

Permit Expiration: In accordance with GS153A-358, building permits expire six months "after the date of issuance if the work authorized by the permit has not commenced", or "after commencement, the work is discontinued for a period of 12 months".

I hereby acknowledge that I have read this permit and state that the above information is correct, and agree to comply with all ordinances and state and federal laws regulating activities covered by this permit.

Residential and Commercial Inspections:  
 Jonathan Briggs, Deputy Director  
 (910) 455-3661

February 26, 2026

\_\_\_\_\_  
 Date

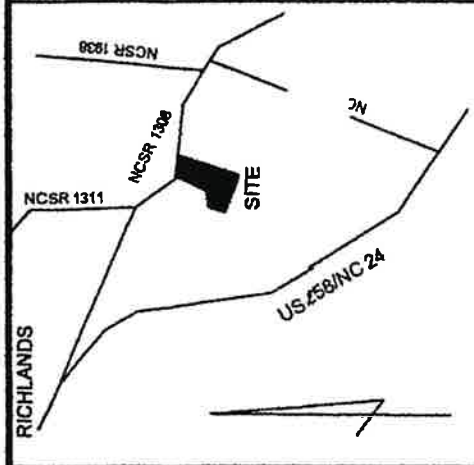

VICINITY MAP - NOT TO SCALE

CURVE	RADIUS	ARC LENGTH	CHORD LENGTH	CHORD BEARING
C1	370.00	9.59	9.59	N 26°29'36" E

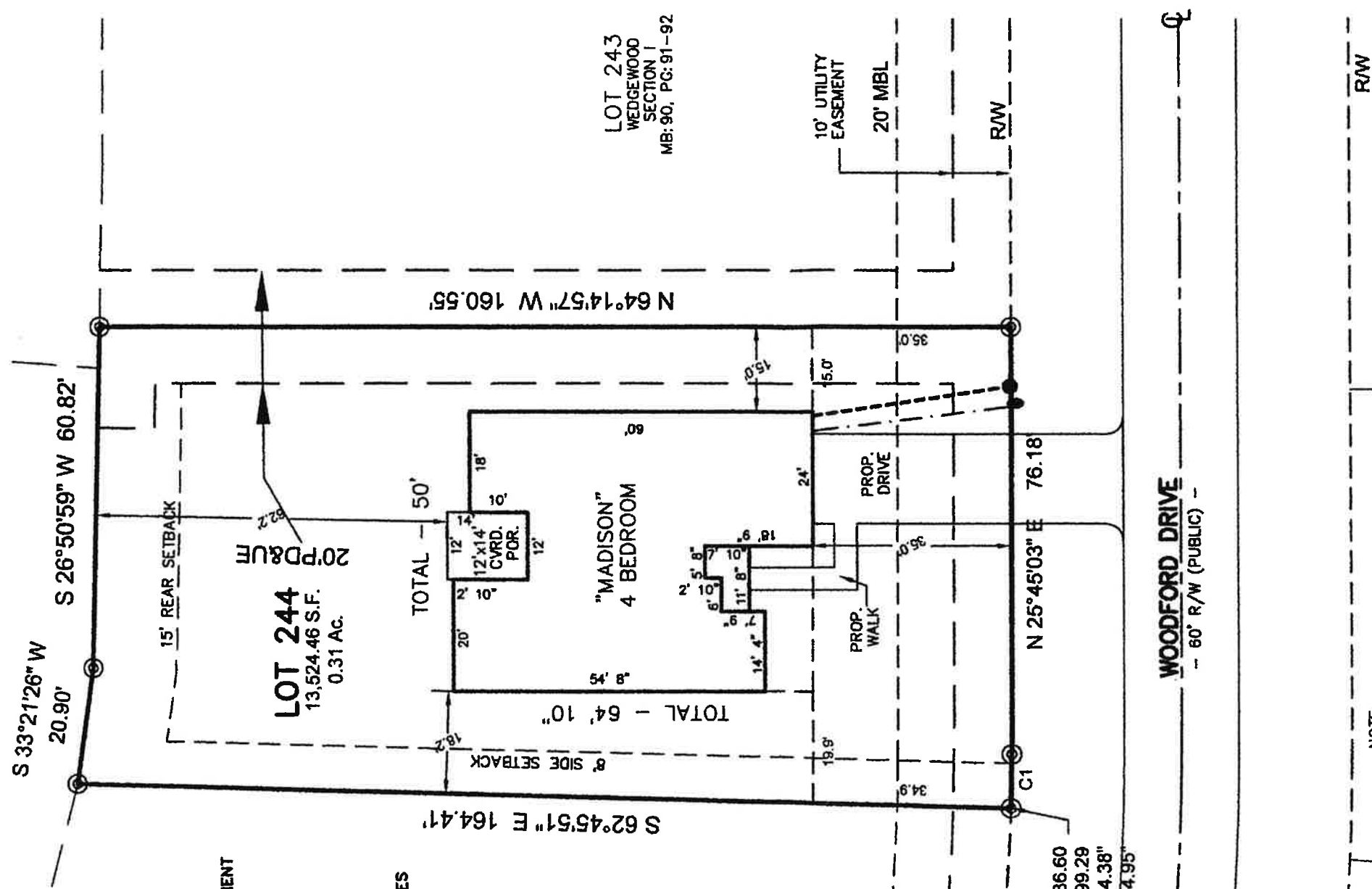

- LEGEND:**
- EXISTING IRON PIPE
  - EXISTING IRON STAKE
  - SET IRON STAKE
  - EXISTING CONCRETE MONUMENT
  - EXISTING PK NAIL
  - MINIMUM BUILDING LINE
  - RIGHT OF WAY
  - EDGE OF PAVEMENT
  - CONCRETE
  - WATER METER
  - POWER POLE
  - SEPTIC TANK
  - PUMP TANK
  - OVERHEAD ELECTRICAL LINES
  - X- FENCE
  - ⊕ CENTERLINE

**REQUIRED SETBACKS:**  
 FRONT: 20'  
 SIDE: 8'  
 CORNER: 20'  
 REAR: 15'

**PROPOSED SETBACKS:**  
 FRONT: 35.0'  
 LEFT SIDE: 18.2'  
 RIGHT SIDE: 15.0'  
 REAR: 62.2'

LOT 245  
 WEDGEWOOD  
 SECTION 1  
 MB: 90, PG: 91-92

LOT 243  
 WEDGEWOOD  
 SECTION 1  
 MB: 90, PG: 91-92

N: 412,236.60  
 E: 2,447,799.29  
 LAT: 34°52'24.38"  
 LON: 77°30'24.95"

ALLOWED BUA: 3,750.00 SQ. FT.  
 PROPOSED BUA: 3,902.53 SQ. FT.  
 AMMENDED BUA TO: 3,850.00 SQ. FT.

**REFERENCES:**

MB: 90, PG: 91-92

**ADDRESS:**

121 WOODFORD DRIVE

**PRELIMINARY PLOT PLAN**

- NOTE:**
- HVAC WILL NOT ENCR OACH INTO SETBACKS.
  - WATER SERVICES PROVIDED BY ONWASA.
  - SEWER SERVICES PROVIDED BY ONWASA.

THIS IS TO CERTIFY THAT THIS MAP IS A TRUE REPRESENTATION OF THE PROPERTY HEREON AS COMPILED BY ACTUAL SURVEY OF THE PREMISES AND THAT THERE ARE NO ENCR OACHMENTS ACCORDING TO THE BEST OF MY KNOWLEDGE, EXCEPT AS SHOWN. THE PROFESSIONAL SEAL IS 1:10,000+.



JOHN L. PIERCE AND SURVEYORS  
 P.L.S., L-2596

LOT NO. 244 BLOCK \_\_\_\_\_  
 SUBDIVISION WEDGEWOOD SECTION 1  
 RICHLANDS TOWNSHIP ONSLOW COUNTY, N.C.  
 PREPARED FOR: ATLANTIC CONSTRUCTION INC.

**JOHN L. PIERCE & ASSOCIATES, P.A. (C-1888)**  
 405 JOHNSON BLVD., JACKSONVILLE, NC 28540  
 PHONE: (910)346-9800 FAX: (910)346-1210

DATE: FEB. 13, 2026 SCALE: 1"= 30'  
 F.B. N/A P. N/A JOB # 2026-103

# Intention to Provide Sewer Service

To: Onslow County Permitting Division

From: Onslow Water and Sewer Authority

## Utility Company name and contact information

Please be advised that we have been granted a Certificate of Public Convenience and Necessity by the North Carolina Utilities Commission to provide sewer utility service to the property described below. It is our intention to provide sewer service pursuant to GS 130A-337.

Property owner: BEAVER CREEK INVESTORS, INC.  
Property address: 121 WOODFORD DR., JACKSONVILLE, NC 28540  
Subdivision: WEDGEWOOD Lot #: 244  
Number of bedrooms: 4  
Any applicable service limitations: N/A

Whitney Miller Whitney Miller 2/10/20  
Authorized Utility Company (Print Name & Signature) Date

## Authorization to Connect to Sewer Service

From: \_\_\_\_\_

## Utility Company name and contact information

Please be advised that the above-described property is authorized to connect pursuant to GS 130A-339.

\_\_\_\_\_  
Authorized Utility Company (Print Name & Signature)

\_\_\_\_\_  
Date



County of Onslow

**Onslow County Central Permitting**  
234 NW Corridor Blvd Jacksonville, NC 28546  
910-455-3661 (office) 910-989-3195 (fax)



# ZONING PERMIT

Applicant: BEAVER CREEK INVESTORS INC  
Property Address: 121 WOODFORD DRIVE, JACKSONVILLE, NC 28540  
Zoning Permit: ZNP-2026-00278/RBLD-2026-00172  
Work Class: Zoning.2  
Parcel #: 54D-75  
Authorized Use: Construct SFD  
Zoning District R-10  
SETBACKS: (Front) 20 (Rear) 15 (Side) 8 (Side Street)

---

Zoning Condition/Standards:

---

Property owners in neighborhoods with restrictive covenants should be aware that the Onslow County Zoning Ordinance may be less restrictive than these covenants. These property owners are advised to contact their Homeowners Association (HOA) prior to construction.

Underpinning/skirting is required for ALL manufactured home setups and must be in place prior to the zoning compliance inspection.

For new construction, the following may have an eighteen (18) inch encroachment allowance:

Ground mounted mechanical equipment, uncovered porches, steps, stoops, overhanging roofs, eaves, bay windows, balconies, gutters, cornices, buttresses, piers, awnings, windowsills, chimneys, covered steps and stoops, structural overhangs, and similar architectural features into required side and rear yard setbacks.

**SETBACK INSPECTION REQUIREMENTS:**

Prior to pouring any concrete, applicants must schedule a setback inspection.

A foundation survey is required for any structure proposed to be within one foot of the required setback line. The applicant is required to accurately mark property lines (flags, stakes, spray paint) prior to the setback inspection. The Zoning Officer can require a foundation survey when he is unable to make a reasonable determination on the setback compliance.

If the structure location is different from the approved site plan, the applicant will be asked to submit a revised site plan that reflects the location.

**FINAL ZONING COMPLIANCE INSPECTION REQUIREMENTS:**

Prior to scheduling final building compliance inspections, the applicant must schedule a final zoning compliance inspection. The Zoning Officer will check for posted address and any changes to the building footprint (additions, porches, etc.) and underpinning for ALL manufactured homes.

Zoning Official: *Eric Barukhorst*

Date: February 23, 2026

This zoning permit shall become invalid six months after the above date if work is not initiated or if work is suspended or abandoned for a period of six months. Any changes in proposed plans, which are unauthorized, shall render this permit void.

**OWNERS' ASSOCIATION DISCLOSURE ADDENDUM**

**NOTE:** For when Residential Property and Owner's Association Disclosure Statement is not required (For example: New Construction, Vacant Lot/Land) or by agreement of the parties.

Property: LOT \_\_\_\_\_ WEDGEWOOD

Buyer: \_\_\_\_\_

Seller: Atlantic Construction Inc

This Addendum is attached to and made a part of the Offer to Purchase and Contract ("Contract") between Buyer and Seller for the Property.

For the purposes of this Addendum, "Development" means any planned community or condominium project, as defined by North Carolina law, which is subject to regulation and assessment by an owners' association.

Any representations made by Seller in this Addendum are true to the best of Seller's knowledge, and copies of any documents provided by Seller are true copies relating to the Development, to the best of Seller's knowledge. Except with regard to Confirmed Special Assessments, Seller does not warrant the accuracy, completeness, or present applicability of any representation or documents provided by Seller, and Buyer is advised to have all information confirmed and any documents substantiated during the Due Diligence Period.

1. Seller represents to Buyer that the Property is subject to the following owners' association(s) [insert N/A into any blank that does not apply]:

(specify name): Wedgewood HOA Inc. whose regular assessments ("dues") are \$300 per year \_\_\_\_\_. The name, address and telephone number of the president of the owners' association or the association manager are: Betty Bullock, President- (910)346-9800  
PO Box 1685, Jacksonville, NC 28541

Owners' association website address, if any: \_\_\_\_\_

(specify name): \_\_\_\_\_ whose regular assessments ("dues") are \$ \_\_\_\_\_ per \_\_\_\_\_. The name, address and telephone number of the president of the owners' association or the association manager are: \_\_\_\_\_

Owners' association website address, if any: \_\_\_\_\_

2. Seller represents to Buyer that the following services and amenities are paid for by the above owners' association(s) from the regular assessments ("dues"): (Check all that apply)

- |                                                                       |                                                                                          |
|-----------------------------------------------------------------------|------------------------------------------------------------------------------------------|
| <input type="checkbox"/> Master Insurance Policy                      | <input type="checkbox"/> Street Lights                                                   |
| <input type="checkbox"/> Real Property Taxes on the Common Areas      | <input type="checkbox"/> Water                                                           |
| <input type="checkbox"/> Casualty/Liability Insurance on Common Areas | <input type="checkbox"/> Sewer                                                           |
| <input type="checkbox"/> Management Fees                              | <input checked="" type="checkbox"/> Private Road Maintenance Access Road to Lift Station |
| <input type="checkbox"/> Exterior Building Maintenance                | <input type="checkbox"/> Parking Area Maintenance                                        |
| <input type="checkbox"/> Exterior Yard/Landscaping Maintenance        | <input type="checkbox"/> Common Areas Maintenance                                        |
| <input type="checkbox"/> Trash Removal                                | <input type="checkbox"/> Cable                                                           |
| <input type="checkbox"/> Pest Treatment/Extermination                 | <input type="checkbox"/> Internet service                                                |
| <input checked="" type="checkbox"/> Legal/Accounting                  | <input checked="" type="checkbox"/> Storm Water Management/Drainage/Ponds                |
|                                                                       | <input type="checkbox"/> Gate and/or Security                                            |

Recreational Amenities (specify): \_\_\_\_\_

Other (specify) \_\_\_\_\_  
 Other (specify) \_\_\_\_\_



This form jointly approved by:  
North Carolina Bar Association  
North Carolina Association of REALTORS®, Inc. Initial



STANDARD FORM 2A12-T  
Revised 7/2021  
© 7/2021

Buyer initials   Seller initials

3. As of this date, there are no other dues, fees or Special Assessments, Confirmed or Proposed, payable by the Development's property owners, except: NA

4. As of this date, there are no unsatisfied judgments against or pending lawsuits involving the Property, the Development and/or the owners' association, except: NA

5. The fees charged by the owners' association or management company in connection with the transfer of Property to a new owner (including but not limited to document preparation, move in/move out fees, preparation of insurance documents, statement of unpaid assessments, and transfer fees) are as follows: NA

6. Seller authorizes and directs any owners' association, any management company of the owners' association, any insurance company and any attorney who has previously represented the Seller to release to Buyer, Buyer's agents, representative, closing attorney or lender true and accurate copies of the following items affecting the Property, including any amendments:

- Seller's statement of account
- master insurance policy showing the coverage provided and the deductible amount
- Declaration and Restrictive Covenants
- Rules and Regulations
- Articles of Incorporation
- Bylaws of the owners' association
- current financial statement and budget of the owners' association
- parking restrictions and information
- architectural guidelines

The parties have read, understand and accept the terms of this Addendum as a part of the Contract.

IN THE EVENT OF A CONFLICT BETWEEN THIS ADDENDUM AND THE CONTRACT, THIS ADDENDUM SHALL CONTROL, EXCEPT THAT IN THE CASE OF SUCH A CONFLICT AS TO THE DESCRIPTION OF THE PROPERTY OR THE IDENTITY OF THE BUYER OR SELLER, THE CONTRACT SHALL CONTROL.

THE NORTH CAROLINA ASSOCIATION OF REALTORS®, INC. AND THE NORTH CAROLINA BAR ASSOCIATION MAKE NO REPRESENTATION AS TO THE LEGAL VALIDITY OR ADEQUACY OF ANY PROVISION OF THIS FORM IN ANY SPECIFIC TRANSACTION. IF YOU DO NOT UNDERSTAND THIS FORM OR FEEL THAT IT DOES NOT PROVIDE FOR YOUR LEGAL NEEDS, YOU SHOULD CONSULT A NORTH CAROLINA REAL ESTATE ATTORNEY BEFORE YOU SIGN IT.

Date: \_\_\_\_\_  
Buyer:

Date: \_\_\_\_\_  
Seller:

Date: \_\_\_\_\_  
Buyer:

Date: \_\_\_\_\_  
Seller:

Entity Buyer: \_\_\_\_\_  
(Name of LLC/Corporation/Partnership/Trust/etc.)

Entity Seller: \_\_\_\_\_  
(Name of LLC/Corporation/Partnership/Trust/etc.)

By:   
Name: \_\_\_\_\_  
Print Name

Signed by:  *Joseph Henderson*  
Name: **Joseph Henderson II**  
Print Name

Title: \_\_\_\_\_

Title: **President**

Date: \_\_\_\_\_

Date: **7/31/2024**



# STATE OF NORTH CAROLINA MINERAL AND OIL AND GAS RIGHTS MANDATORY DISCLOSURE STATEMENT

## Instructions to Property Owners

1. The Residential Property Disclosure Act (G.S. 47E) ("Disclosure Act") requires owners of certain residential real estate such as single-family homes, individual condominiums, townhouses, and the like, and buildings with up to four dwelling units, to furnish purchasers a Mineral and Oil and Gas Rights Disclosure Statement ("Disclosure Statement"). This form is the only one approved for this purpose.
2. A disclosure statement is not required for some transactions. For a complete list of exemptions, see G.S. 47E-2(a). **A DISCLOSURE STATEMENT IS REQUIRED FOR THE TRANSFERS IDENTIFIED IN G.S. 47E-2(b)**, including transfers involving the first sale of a dwelling never inhabited, lease with option to purchase contracts where the lessee occupies or intends to occupy the dwelling, and transfers between parties when both parties agree not to provide the Residential Property and Owner's Association Disclosure Statement.
3. You must respond to each of the following by placing a check  in the appropriate box.

## MINERAL AND OIL AND GAS RIGHTS DISCLOSURE

Mineral rights and/or oil and gas rights can be severed from the title to real property by conveyance (deed) of the mineral rights and/or oil and gas rights from the owner or by reservation of the mineral rights and/or oil and gas rights by the owner. If mineral rights and/or oil and gas rights are or will be severed from the property, the owner of those rights may have the perpetual right to drill, mine, explore, and remove any of the subsurface mineral and/or oil or gas resources on or from the property either directly from the surface of the property or from a nearby location. With regard to the severance of mineral rights and/or oil and gas rights, Seller makes the following disclosures:

	Yes	No	No Representation
<input type="text"/> <input type="text"/> Buyer Initials	<input type="checkbox"/>	<input type="checkbox"/>	<input checked="" type="checkbox"/>
1. Mineral rights were severed from the property by a previous owner.			
<input type="text"/> <input type="text"/> Buyer Initials	<input type="checkbox"/>	<input checked="" type="checkbox"/>	<input type="checkbox"/>
2. Seller has severed the mineral rights from the property.			
<input type="text"/> <input type="text"/> Buyer Initials	<input type="checkbox"/>	<input checked="" type="checkbox"/>	<input type="checkbox"/>
3. Seller intends to sever the mineral rights from the property prior to transfer of title to the Buyer.			
<input type="text"/> <input type="text"/> Buyer Initials	<input type="checkbox"/>	<input type="checkbox"/>	<input checked="" type="checkbox"/>
4. Oil and gas rights were severed from the property by a previous owner.			
<input type="text"/> <input type="text"/> Buyer Initials	<input type="checkbox"/>	<input checked="" type="checkbox"/>	<input type="checkbox"/>
5. Seller has severed the oil and gas rights from the property.			
<input type="text"/> <input type="text"/> Buyer Initials	<input type="checkbox"/>	<input checked="" type="checkbox"/>	<input type="checkbox"/>
6. Seller intends to sever the oil and gas rights from the property prior to transfer of title to Buyer.			

## Note to Purchasers

If the owner does not give you a Mineral and Oil and Gas Rights Disclosure Statement by the time you make your offer to purchase the property, or exercise an option to purchase the property pursuant to a lease with an option to purchase, you may under certain conditions cancel any resulting contract without penalty to you as the purchaser. To cancel the contract, you must personally deliver or mail written notice of your decision to cancel to the owner or the owner's agent within three calendar days following your receipt of this Disclosure Statement, or three calendar days following the date of the contract, whichever occurs first. However, in no event does the Disclosure Act permit you to cancel a contract after settlement of the transaction or (in the case of a sale or exchange) after you have occupied the property, whichever occurs first.

Property Address: Lot \_\_\_\_\_ Wedgwood \_\_\_\_\_

Owner's Name(s): Atlantic Construction Inc \_\_\_\_\_

Owner(s) acknowledge having examined this Disclosure Statement before signing and that all information is true and correct as of the date signed.

Owner Signature: DocuSigned by: Joseph Henderson Date 4/24/2024

Owner Signature: 944A935C3A3A482... Date \_\_\_\_\_

Purchaser(s) acknowledge receipt of a copy of this Disclosure Statement; that they have examined it before signing; that they understand that this is not a warranty by owner or owner's agent; and that the representations are made by the owner and not the owner's agent(s) or subagent(s).

Purchaser Signature: \_\_\_\_\_ Date \_\_\_\_\_

Purchaser Signature: \_\_\_\_\_ Date \_\_\_\_\_

**NEW CONSTRUCTION ADDENDUM**

OFFER TO PURCHASE AND CONTRACT, DATED \_\_\_\_\_ BETWEEN

**SELLER/BUILDER:** ATLANTIC CONSTRUCTION, INC., a North Carolina corporation

**BUYER:** \_\_\_\_\_  
(whether one or more)

**LEGAL DESCRIPTION:** \_\_\_\_\_  
(the "Property")

The BUYER and SELLER acknowledge and agree to the following:

- 1) SELLER agrees to pay, or have paid, up to \$ \_\_\_\_\_ or \_\_\_\_\_ % of Purchase Price of BUYER'S expenses associated with the purchase of the Property (the "Closing Costs"). BUYER shall be responsible for all costs and expenses that exceed the amount stated above. Notwithstanding the foregoing provisions, SELLER'S obligation to pay any Closing Costs is contingent upon BUYER selecting the law firm of Gaylor Edwards & Vatcher, P.A., whose address is 219 New Bridge Street, Jacksonville, NC 28540, or such other attorney designated by SELLER, as the closing attorney. BUYER hereby acknowledges receipt of the Gaylor Edwards & Vatcher, P.A. engagement letter.

The "Prorations and Adjustments" Section of the Contract is hereby amended by inserting the following sentence at the end of said Section: Notwithstanding the foregoing provisions, if all or any of the property taxes for the year in which closing occurs are escrowed, the SELLER and BUYER agree that there will not be an additional proration or adjustment for SELLER'S share of the property taxes for the year in which closing occurs.

- 2) BUYER'S Loan Pre-Approval and/or Prequalification must accompany this Offer to Purchase/Contract. BUYER agrees to close the purchase of the Property within seven (7) working days following satisfactory completion of the final inspection by the requisite governmental authority, and/or BUILDER is in receipt of the Certificate of Occupancy issued by the requisite governmental authority.
- 3) BUILDER will exercise its best efforts to enable BUYER to close on or before the Closing Date set forth in the Contract; however, in the event closing occurs after the Closing Date, neither the REALTORS nor BUILDER shall be liable for any damages, monetary or otherwise, including, but not limited to, BUYER'S temporary lodging expenses, additional cost for storage expenses, interest rate lock extension costs and/or any additional fees, costs or expenses BUYER may incur for his/her/their loan, for any delay or postponements of the Closing, resulting from unforeseen events, weather conditions or other conditions beyond the BUILDER'S control which may delay completion of construction and/or Closing.
- 4) Upon execution of the Offer to Purchase and Contract and this Addendum by SELLER and BUYER, BUYER authorizes BUYER'S lender to provide SELLER with a copy of BUYER'S appraisal report of the Property and to discuss with SELLER and SELLER'S AGENTS details of the loan with regard to the status of approval and Closing.
- 5) BUILDER has built, and/or will build, \_\_\_\_\_ floor plan (the "Floor Plan") and BUYER **may, or may not, in BUILDER'S discretion**, be able or allowed to make selections or upgrades from BUILDER'S Inventory (depending upon the stage of construction of the dwelling, and whether the materials have already been ordered).
- 6) Any upgrades, changes or additions ("Change Requests") to the Floor Plan or other proposed improvements to the Property must be agreed to by SELLER, in writing, and paid for by BUYER, in advance, on or before the date agreed to for payment by SELLER and BUYER (the "Change Request Payment Deadline"). All monies paid for

\_\_\_\_\_  
Buyer's Initials

\_\_\_\_\_  
Buyer's Initials

\_\_\_\_\_  
Seller's Initials

\_\_\_\_\_  
Seller's Initials

such Change Requests are non-refundable, whether closing occurs or not, **unless** same are included in the SELLER'S contribution toward BUYER'S Closing Costs, allowances and physical improvements, and SELLER agrees to same in writing. In the event BUYER fails to pay for the Change Requests on or before the Change Request Payment Deadline, or such other date agreed to by SELLER, in writing, prior thereto, the Change Requests shall be deemed cancelled, and the Contract shall be enforceable in accordance with the terms therein without the Change Requests. The charges for any upgrades, changes or additions to be paid from SELLER'S agreed contribution to BUYER'S Closing Costs shall be paid by BUYER to SELLER in the event Closing does not occur for any reason at the time of termination of the Contract.

- 7) BUYER acknowledges it understands and agrees that renderings of the Floor Plan and elevations may differ slightly from actual completed construction of the house and improvements. All photos on the website and MLS are of similar model houses. Drawings are artist's renderings only and are NOT to be considered 100% representative of actual houses. Floor Plans vary in regard to square footage and details. Due to requests, options and specification changes, by other purchasers of houses from BUILDER, the items viewed in such other houses may not be the exact manner of construction for BUYER'S house.
- 8) ALL BUYER'S questions and requests will be directed to the BUILDER'S AGENT through the BUYER'S REALTOR. Information provided by workers on the job site, non-supervisory employees of the BUILDER, or other persons without the express written authorization of the BUILDER, are not authorized by, nor binding on, the BUILDER.
- 9) BUYER understands and agrees that the One-Year Builder's Warranty (the "Warranty") shall be effective for a period of one (1) year from the date of initial occupancy by BUYER, or the date of closing, whichever shall occur first. BUYER also understands that the Warranty covers structural defects which affect habitation of the dwelling, along with the electrical, plumbing, heating and air conditioning systems. BUYER acknowledges that the Warranty does not include accidental or intentional damage, misuse, abuse, normal wear and tear, cosmetic items, decorative items or yard landscaping, and specifically excluded are Paint, Screens and Small Concrete Cracks. Landscaping that has been performed by BUILDER shall be deemed complete at the earlier to occur of initial occupancy or the date of Closing, unless otherwise agreed to by the parties, in writing. Any erosion that occurs, and the costs of repairing same, after the earlier to occur of the initial date of occupancy or the date of closing, shall be the sole responsibility of BUYER.
- 10) BUYER acknowledges that he/she/they have received a copy of the Restrictive Covenants, Septic System and Exclusive Easements Agreement, and Sewer Authorization, if applicable, affecting the Property [the "Restriction Document(s)] at time of delivery of the Offer to Purchase to SELLER; BUYER understands that it is his/her/their responsibility to read the Restriction Documents and obtain answers to any questions regarding same, prior to Closing. Closing shall constitute BUYER'S acknowledgment of his/her/their obligation to comply with the terms of the Restriction Documents.
- 11) BUYER acknowledges being informed that land in the subdivision in which the Property is situated, has been designated jurisdictional "404 Wetlands," by the US Army Corps of Engineers and that said "404 Wetlands" are restricted from hydrological disturbance. The BUYER further acknowledges he/she/they have reviewed the recorded plat of the subdivision which includes a description of the Property and is aware of whether or not any portion of the Property contains "404 Wetlands".
- 12) BUYER acknowledges that prior to execution of the Offer to Purchase and Contract, he/she/they have been informed that there **may** be a Military Firing Range, and/or airport, in close proximity to the Property.
- 13) BUYER acknowledges that common boundary line fencing may be connected to fencing by adjoining lot owners, if the Restrictive Covenants permit, or if SELLER installs or contributes to the cost of any fence for the Property. By execution of this Addendum, BUYER hereby grants permission for any fence erected on the Property to be tied into, butted up to or connected to, whether existing fence or future fencing along or within one (1) foot of the property lot lines. This provision shall survive Closing and is enforceable by SELLER, or its successors or assigns.

\_\_\_\_\_  
Buyer's Initials

\_\_\_\_\_  
Buyer's Initials

\_\_\_\_\_  
Seller's Initials

\_\_\_\_\_  
Seller's Initials

- 14) The BUYER is responsible for applying for and obtaining electric service and water service prior to moving in, and coordinating service with the date of occupancy or Closing. BUYER also acknowledges that BUYER is solely responsible for determining the school districts in which the Property is situated.
- 15) BUYER acknowledges that, unless otherwise agreed in writing, the BUILDER will not deliver possession of the Property to BUYER until the deed of conveyance thereof has been recorded in the Office of the Onslow County Register of Deeds and funds have been disbursed by the closing attorney.
- 16) BUYER agrees that either BUYER or BUYER'S Representative will be present at the BUILDER walk-thru, (to be scheduled by a BUILDER Representative on a date, and time agreed upon by both parties). The walk-thru is for the purpose of identifying punch list items to be completed prior to, or soon after, Closing and BUYER needs to allow a minimum of one (1) hour for completion of the walk-thru.
- 17) In accordance with the BUILDER'S Insurance Policy and NC State Law:
  - a. BUYER understands and agrees that he/she/they will not be on the job site, unless accompanied by a REALTOR or the BUILDER or a BUILDER'S Representative.
  - b. BUYER understands that he/she/ they enter the job site at their own risk.
  - c. BUYER may not engage any tradesman to make additions or upgrades to the structure prior to Closing..
- 18) BUYER acknowledges that one or more of BUILDER'S AGENTS and/or OFFICERS have a valid NC Real Estate License.

**IN THE EVENT OF A CONFLICT BETWEEN THIS ADDENDUM AND THE OFFER TO PURCHASE AND CONTRACT, OR ANY OTHER ADDENDUM, THIS ADDENDUM SHALL CONTROL.**

**BUYER:** \_\_\_\_\_ **(Seal)** **DATE:** \_\_\_\_\_

**BUYER:** \_\_\_\_\_ **(Seal)** **DATE:** \_\_\_\_\_

**SELLER:** ATLANTIC CONSTRUCTION, INC.

**By:** \_\_\_\_\_ **DATE:** \_\_\_\_\_

\_\_\_\_\_  
Buyer's Initials

\_\_\_\_\_  
Buyer's Initials

\_\_\_\_\_  
Seller's Initials

\_\_\_\_\_  
Seller's Initials

6/21/19



www.AtlanticConstructionInc.com | 910.938.9053

## Wedgewood

### **DESIGN FEATURES**

#### **Exterior Features**

- \* 2x4 wall construction with ceiling heights varying per plan
- \* 7/16" OSB sheathing exterior walls and roof
- \* Continuous concrete footing with a concrete slab
- \* Low maintenance vinyl siding in custom colors
- \* Flat-panel or louvered shutters on front elevation
- \* Limited Lifetime architectural shingles
- \* Custom culture stone veneer accent per plan
- \* Vinyl single hung windows--tilt-sash, insulated and low-E with custom grill patterns and screens
- \* Concrete driveway and front walk
- \* Spacious rear patio or covered porch per plan
- \* 2 exterior hose bibs & weatherproof electrical outlets
- \* Entire house water shut off valve at house and an additional cut off valve at water meter
- \* overhead garage door with opener
- \* Interior of garage walls, finished and primed
- \* Lockset with security deadbolts on all exterior doors in Black finish
- \* Professional landscaping to include sod in front yard(400 sqyd) with seeded sides and up to 40' at rear of home

#### **Kitchen Features**

- \* Flat panel cabinets with crown molding and decorative door knobs
- \* Smooth top self-cleaning range, microwave hood over range, and dishwasher(stainless/black)
- \* Granite or Quartz countertops from builders selections

#### **Bath Features**

- \* Fiberglass tub and shower per plan
- \* Relaxing soaking tub in master bath per plan
- \* Black bathroom accessories to include bath hardware and plumbing and lighting fixtures
- \* Flat panel vanities with cultured marble tops and full-view glass mirrors

#### **Energy Saving Features**

- \* Energy efficient insulation--R15 walls and R38 Ceiling
- \* 14-Seer heat pump with digital thermostat - plan specific
- \* Full soffit and roof ridge ventilation
- \* Energy efficient 50-gallon electric water heater

#### **Interior Features**

- \* Smooth finish gypsum ceilings
- \* Vaulted or tray ceilings in master bedroom per plan
- \* Decorative lighting package with Black finish
- \* Ceiling fan with light installed in family room with all bedrooms pre-wired for ceiling fans
- \* Specific homes with electric fireplace
- \* Black hinges and door knobs
- \* Cable outlet and cat5 in family room and dedicated cat5 in bedrooms and any bonus room, with one phone jack in kitchen
- \* Ventilated shelving in closets
- \* Flooring--carpet with 6 lb. padding and luxury vinyl plank per plan
- \* Smooth panel interior doors
- \* Smoke detectors in all bedrooms, any bonus room, and hallways with hardwired battery back-up
- \* Carbon monoxide detector

#### **Customer Care and Warranty**

- \* Full-time warranty staff and customer care contact associate
- \* One-year home warranty

6/21/19

\* Home orientation with builder and buyer at home

CURVE	RADIUS	ARC LENGTH	CHORD LENGTH	CHORD BEARING	LINE BEARING	DISTANCE
C1	1206.24	133.35	133.28	S 62°52'30" E	L1	N 02°47'46" E 74.42
C2	1206.24	117.31	117.31	S 60°07'10" E	L2	S 66°03'05" E 20.35
C3	1206.24	117.31	117.31	S 60°07'10" E	L3	N 08°30'10" E 110.39
C4	1206.24	60.45	60.45	S 62°01'38" E		
C5	1206.24	27.48	27.48	S 84°06'55" E		
C6	1206.24	26.84	26.84	S 65°24'17" E		
C7	280.00	156.17	156.08	S 29°17'22" W		
C8	340.00	249.03	243.50	S 44°26'00" W		
C9	20.00	31.42	28.28	S 20°24'58" W		
C10	20.00	31.42	28.28	N 69°35'02" W		
C11	570.00	256.15	251.06	S 48°53'00" W		
C12	20.00	29.88	27.17	S 88°39'14" E		
C13	20.00	29.88	27.17	S 88°15'28" W		
C14	630.00	119.74	119.56	S 31°11'44" W		
C15	630.00	101.50	101.39	S 50°34'56" W		
C16	20.00	29.27	26.73	S 12°24'54" W		
C17	260.00	110.61	109.77	S 16°59'02" E		
C18	200.00	123.75	121.79	N 06°13'23" W		
C19	20.00	31.44	28.30	N 77°59'54" W		
C20	340.00	107.29	106.84	S 72°01'33" W		
C21	20.00	31.42	28.28	S 36°03'57" W		
C22	410.00	198.41	196.48	S 04°55'46" W		
C23	280.00	187.53	185.04	S 01°35'10" W		
C24	25.00	20.32	19.76	S 38°48'18" E		
C25	55.00	26.19	25.62	S 74°30'45" W		
C26	25.00	20.32	19.76	S 07°47'46" E		
C27	340.00	203.43	200.40	N 02°29'10" E		
C28	350.00	169.38	167.73	N 04°58'16" E		
C29	20.00	31.42	28.28	S 53°56'03" E		
C30	280.00	128.87	127.74	N 67°52'49" E		
C31	470.00	287.95	284.90	N 40°13'02" E		
C32	430.00	297.69	291.78	N 45°03'02" E		
C33	280.00	205.08	200.53	N 44°28'00" E		
C34	340.00	68.21	68.09	N 29°11'52" E		
C35	280.00	3.89	3.89	S 34°33'52" W		
C36	280.00	52.29	52.21	S 28°48'02" W		
C37	340.00	40.48	40.45	S 26°51'41" W		
C38	340.00	77.95	77.78	S 36°50'24" W		
C39	340.00	77.95	77.78	S 49°58'53" W		
C40	340.00	52.65	52.60	S 60°58'48" W		
C41	370.00	38.94	38.92	S 62°24'05" W		
C42	370.00	103.81	103.47	S 51°20'58" W		
C43	370.00	103.81	103.47	S 35°16'25" W		
C44	370.00	9.59	9.59	S 26°29'56" W		
C45	630.00	42.69	42.68	S 27°41'31" W		
C46	630.00	77.05	77.00	S 33°08'12" W		
C47	630.00	77.05	77.00	S 46°32'26" W		
C48	630.00	33.84	33.83	S 43°09'22" W		
C49	280.00	47.40	47.33	S 23°56'53" E		
C50	280.00	63.21	63.05	S 11°45'40" E		
C51	410.00	58.79	58.70	S 04°49'45" E		
C52	410.00	74.16	74.06	S 04°27'28" E		
C53	410.00	65.50	65.43	S 14°12'59" W		
C54	280.00	11.07	11.07	S 17°39'36" W		
C55	280.00	119.45	118.54	S 04°18'21" W		
C56	280.00	37.01	36.98	S 11°22'02" E		
C57	55.00	33.11	32.81	S 44°48'38" E		
C58	55.00	57.74	55.12	S 02°30'26" W		
C59	55.00	12.45	12.45	S 54°44'24" E		
C60	55.00	30.38	30.00	N 87°20'19" E		
C61	55.00	98.42	85.80	N 20°11'00" W		
C62	340.00	21.31	21.30	N 13°41'32" W		
C63	340.00	87.04	86.80	N 40°47'15" E		
C64	340.00	95.08	94.77	N 04°33'48" W		
C65	350.00	7.64	7.64	N 18°10'03" E		
C66	350.00	110.61	110.15	N 08°29'19" E		
C67	350.00	151.13	151.08	N 04°44'58" W		
C68	280.00	63.03	62.99	N 61°25'55" E		
C69	280.00	65.85	65.69	N 61°25'55" E		
C70	570.00	92.35	92.25	N 50°03'13" E		
C71	570.00	92.02	91.92	N 44°20'19" E		
C72	570.00	91.51	91.41	N 27°00'19" E		
C73	570.00	12.08	12.08	N 26°21'28" E		
C74	430.00	18.83	18.83	N 27°00'19" E		
C75	430.00	80.45	80.33	N 33°37'10" E		
C76	430.00	80.45	80.33	N 44°20'19" E		
C77	430.00	80.45	80.33	N 55°03'28" E		
C78	430.00	37.51	37.50	N 82°55'00" E		
C79	340.00	52.73	52.67	N 27°53'36" E		
C80	340.00	15.48	15.48	N 33°38'25" E		

CERTIFICATE OF APPROVAL FOR RECORDING

I HEREBY CERTIFY THAT THE SUBDIVISION PLAT SHOWN HEREON HAS BEEN FOUND TO COMPLY WITH SUBDIVISION REGULATIONS OF THE COUNTY OF ONSLOW, NORTH CAROLINA, AND THAT THIS PLAT HAS BEEN APPROVED BY THE ONSLOW COUNTY PLANNING DEPARTMENT FOR RECORDING IN THE OFFICE OF THE REGISTER OF DEEDS OF ONSLOW COUNTY.

2/21/24 *John L. Pierce*  
DATE SUBDIVISION ADMINISTRATOR

2/20/24 *John L. Pierce*  
DATE OWNER/AUTHORIZED AGENT

DEPARTMENT OF TRANSPORTATION DIVISION OF HIGHWAYS PROPOSED SUBDIVISION ROAD CONSTRUCTION STANDARDS CERTIFICATE

*Hinton R. Spivey* 2/20/24  
APPROVED DISTRICT ENGINEER

ALL STREETS HEREON HAVE BEEN OFFERED TO THE STATE FOR DEDICATION TO PUBLIC USE, BUT HAVE NOT BEEN ACCEPTED BY THE STATE AS OF THIS DATE. THE DEVELOPER SHALL IMMEDIATELY PETITION THE NORTH CAROLINA DEPARTMENT OF TRANSPORTATION TO ACCEPT STREETS UPON CONSTRUCTION OF THE STREETS AND SATISFACTION OF THE DEPARTMENT'S RESIDENCY REQUIREMENTS. THE DEVELOPER SHALL BE RESPONSIBLE FOR MAINTENANCE OF ALL STREETS AND PROTECTION OF RIGHTS-OF-WAY UNTIL SUCH STREETS ARE ACCEPTED INTO THE STATE ROAD SYSTEM. THE DEVELOPER HAS PROVIDED THE COUNTY A MAINTENANCE GUARANTEE FOR THESE PURPOSES.

I, JOHN L. PIERCE, CERTIFY THAT THIS PLAT WAS DRAWN UNDER MY SUPERVISION FROM AN ACTUAL SURVEY MADE UNDER MY SUPERVISION (DEED REFERENCES SHOWN HEREON); THAT THE BOUNDARIES NOT SURVEYED ARE CLEARLY INDICATED; THAT THE RATIO OF PRECISION AS CALCULATED IS 1:10,000; THAT THIS PLAT WAS PREPARED IN ACCORDANCE WITH G.S. 47-30-30 AS AMENDED. WITNESS MY ORIGINAL SIGNATURE, LICENSE NUMBER AND SEAL THIS DAY OF *Feb* 2024.

JOHN L. PIERCE P.L.S. L-2596

NORTH CAROLINA PROFESSIONAL LAND SURVEYOR SEAL L-2596 JOHN L. PIERCE

I, A NOTARY PUBLIC IN AND FOR THE COUNTY AND STATE AFORESAID, CERTIFY THAT I AM A QUALIFIED PROFESSIONAL LAND SURVEYOR, PERSONALLY APPEARED BEFORE ME THIS *16* DAY OF *February* 2024, AND ACKNOWLEDGED THE EXECUTION OF THE FOREGOING INSTRUMENT. WITNESS MY HAND AND OFFICIAL SEAL, THIS *16* DAY OF *February* 2024.

COMMISSION EXPIRES ON *SEPTEMBER 28, 2028*

*John L. Pierce*  
NOTARY PUBLIC

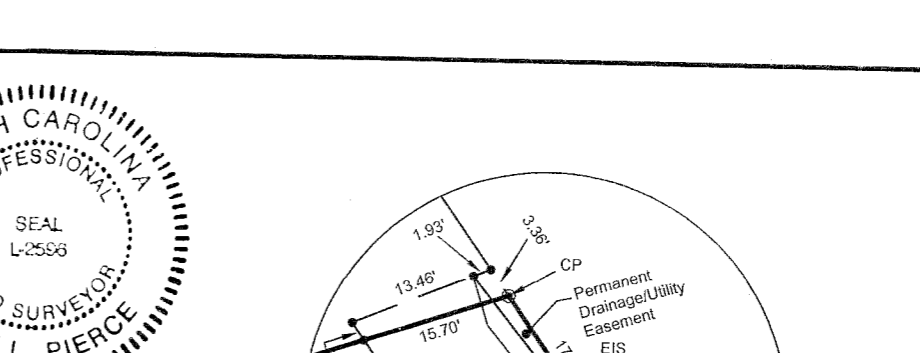

STATE OF NORTH CAROLINA COUNTY OF ONSLOW

*Julianne T. Baker*  
REVIEW OFFICER OF ONSLOW COUNTY

*Julianne T. Baker* 2/21/24  
REVIEW OFFICER DATE

I, JOHN L. PIERCE, PROFESSIONAL LAND SURVEYOR NO. 2596, CERTIFY TO ONE OR MORE OF THE FOLLOWING AS INDICATED:

A. THAT THIS PLAT IS OF A SURVEY THAT CREATES A SUBDIVISION OF LAND WITHIN THE AREA OF A COUNTY OR MUNICIPALITY THAT HAS AN ORDINANCE THAT REGULATES PARCELS OF LAND.

NIF NICOLETTE A. TAYLOR & HUSBAND ZACHARY D. TAYLOR D.B. 8511 P. 462 LOT 2 M.B. 59 P. 42 ZONED RA RESIDENTIAL USE

*John L. Pierce*  
JOHN L. PIERCE, PROFESSIONAL LAND SURVEYOR NO. 2596

NORTH CAROLINA PROFESSIONAL LAND SURVEYOR SEAL L-2596 JOHN L. PIERCE

I, JOHN L. PIERCE, PROFESSIONAL LAND SURVEYOR NO. 2596, CERTIFY TO ONE OR MORE OF THE FOLLOWING AS INDICATED:

A. THAT THIS PLAT IS OF A SURVEY THAT CREATES A SUBDIVISION OF LAND WITHIN THE AREA OF A COUNTY OR MUNICIPALITY THAT HAS AN ORDINANCE THAT REGULATES PARCELS OF LAND.

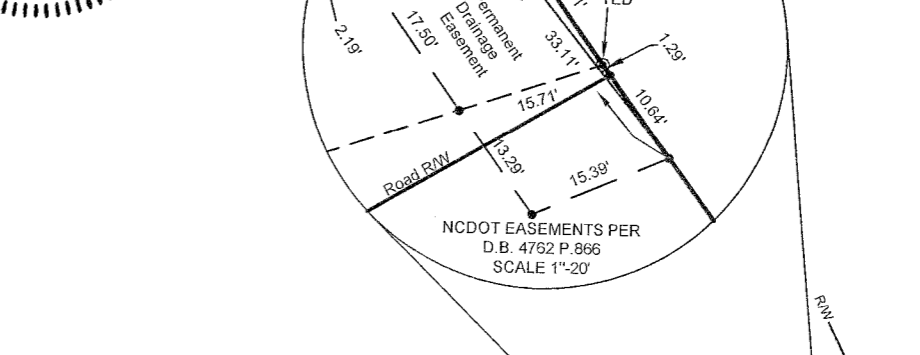

NIF BONNIE B. FREDRICK TRACT ONE D.B. 970 P. 419 ZONED RA RESIDENTIAL WOODED USE

*John L. Pierce*  
JOHN L. PIERCE, PROFESSIONAL LAND SURVEYOR NO. 2596

NIF BEAVER CREEK INVESTORS, INC. D.B. 5198 P. 941 M.B. 77 P. 235 ZONED R-10 FUTURE RESIDENTIAL

*John L. Pierce*  
JOHN L. PIERCE, PROFESSIONAL LAND SURVEYOR NO. 2596

NIF BEAVER CREEK INVESTORS, INC. D.B. 5198 P. 941 M.B. 77 P. 235 ZONED R-10 FUTURE RESIDENTIAL

*John L. Pierce*  
JOHN L. PIERCE, PROFESSIONAL LAND SURVEYOR NO. 2596

NIF JON M. HACKETT & WIFE LILA C. HACKETT D.B. 2119 P. 227 ZONED RA RESIDENTIAL USE

NIF ROBERT E. SMITH D.B. 1058 P. 591 ZONED R-10 RESIDENTIAL USE

NIF GEORGE BROWN & WIFE SUSANNE C. BROWN D.B. 1176 P. 963 ZONED RA RESIDENTIAL USE

NIF BONNIE B. FREDRICK TRACT ONE D.B. 970 P. 419 ZONED RA RESIDENTIAL WOODED USE

*John L. Pierce*  
JOHN L. PIERCE, PROFESSIONAL LAND SURVEYOR NO. 2596

NIF BEAVER CREEK INVESTORS, INC. D.B. 5198 P. 941 M.B. 77 P. 235 ZONED R-10 FUTURE RESIDENTIAL

*John L. Pierce*  
JOHN L. PIERCE, PROFESSIONAL LAND SURVEYOR NO. 2596

NIF BEAVER CREEK INVESTORS, INC. D.B. 5198 P. 941 M.B. 77 P. 235 ZONED R-10 FUTURE RESIDENTIAL

*John L. Pierce*  
JOHN L. PIERCE, PROFESSIONAL LAND SURVEYOR NO. 2596

NIF JON M. HACKETT & WIFE LILA C. HACKETT D.B. 2119 P. 227 ZONED RA RESIDENTIAL USE

NIF ROBERT E. SMITH D.B. 1058 P. 591 ZONED R-10 RESIDENTIAL USE

NIF GEORGE BROWN & WIFE SUSANNE C. BROWN D.B. 1176 P. 963 ZONED RA RESIDENTIAL USE

NIF BONNIE B. FREDRICK TRACT ONE D.B. 970 P. 419 ZONED RA RESIDENTIAL WOODED USE

*John L. Pierce*  
JOHN L. PIERCE, PROFESSIONAL LAND SURVEYOR NO. 2596

NIF BEAVER CREEK INVESTORS, INC. D.B. 5198 P. 941 M.B. 77 P. 235 ZONED R-10 FUTURE RESIDENTIAL

*John L. Pierce*  
JOHN L. PIERCE, PROFESSIONAL LAND SURVEYOR NO. 2596

NIF BEAVER CREEK INVESTORS, INC. D.B. 5198 P. 941 M.B. 77 P. 235 ZONED R-10 FUTURE RESIDENTIAL

*John L. Pierce*  
JOHN L. PIERCE, PROFESSIONAL LAND SURVEYOR NO. 2596

NIF JON M. HACKETT & WIFE LILA C. HACKETT D.B. 2119 P. 227 ZONED RA RESIDENTIAL USE

NIF ROBERT E. SMITH D.B. 1058 P. 591 ZONED R-10 RESIDENTIAL USE

NIF GEORGE BROWN & WIFE SUSANNE C. BROWN D.B. 1176 P. 963 ZONED RA RESIDENTIAL USE

NIF BONNIE B. FREDRICK TRACT ONE D.B. 970 P. 419 ZONED RA RESIDENTIAL WOODED USE

*John L. Pierce*  
JOHN L. PIERCE, PROFESSIONAL LAND SURVEYOR NO. 2596

NIF BEAVER CREEK INVESTORS, INC. D.B. 5198 P. 941 M.B. 77 P. 235 ZONED R-10 FUTURE RESIDENTIAL

*John L. Pierce*  
JOHN L. PIERCE, PROFESSIONAL LAND SURVEYOR NO. 2596

NIF BEAVER CREEK INVESTORS, INC. D.B. 5198 P. 941 M.B. 77 P. 235 ZONED R-10 FUTURE RESIDENTIAL

*John L. Pierce*  
JOHN L. PIERCE, PROFESSIONAL LAND SURVEYOR NO. 2596

NIF JON M. HACKETT & WIFE LILA C. HACKETT D.B. 2119 P. 227 ZONED RA RESIDENTIAL USE

NIF ROBERT E. SMITH D.B. 1058 P. 591 ZONED R-10 RESIDENTIAL USE

NIF GEORGE BROWN & WIFE SUSANNE C. BROWN D.B. 1176 P. 963 ZONED RA RESIDENTIAL USE

NIF BONNIE B. FREDRICK TRACT ONE D.B. 970 P. 419 ZONED RA RESIDENTIAL WOODED USE

*John L. Pierce*  
JOHN L. PIERCE, PROFESSIONAL LAND SURVEYOR NO. 2596

NIF BEAVER CREEK INVESTORS, INC. D.B. 5198 P. 941 M.B. 77 P. 235 ZONED R-10 FUTURE RESIDENTIAL

*John L. Pierce*  
JOHN L. PIERCE, PROFESSIONAL LAND SURVEYOR NO. 2596

NIF BEAVER CREEK INVESTORS, INC. D.B. 5198 P. 941 M.B. 77 P. 235 ZONED R-10 FUTURE RESIDENTIAL

*John L. Pierce*  
JOHN L. PIERCE, PROFESSIONAL LAND SURVEYOR NO. 2596

NIF JON M. HACKETT & WIFE LILA C. HACKETT D.B. 2119 P. 227 ZONED RA RESIDENTIAL USE

NIF ROBERT E. SMITH D.B. 1058 P. 591 ZONED R-10 RESIDENTIAL USE

NIF GEORGE BROWN & WIFE SUSANNE C. BROWN D.B. 1176 P. 963 ZONED RA RESIDENTIAL USE

NIF BONNIE B. FREDRICK TRACT ONE D.B. 970 P. 419 ZONED RA RESIDENTIAL WOODED USE

*John L. Pierce*  
JOHN L. PIERCE, PROFESSIONAL LAND SURVEYOR NO. 2596

NIF BEAVER CREEK INVESTORS, INC. D.B. 5198 P. 941 M.B. 77 P. 235 ZONED R-10 FUTURE RESIDENTIAL

*John L. Pierce*  
JOHN L. PIERCE, PROFESSIONAL LAND SURVEYOR NO. 2596

NIF BEAVER CREEK INVESTORS, INC. D.B. 5198 P. 941 M.B. 77 P. 235 ZONED R-10 FUTURE RESIDENTIAL

*John L. Pierce*  
JOHN L. PIERCE, PROFESSIONAL LAND SURVEYOR NO. 2596

NIF JON M. HACKETT & WIFE LILA C. HACKETT D.B. 2119 P. 227 ZONED RA RESIDENTIAL USE

NIF ROBERT E. SMITH D.B. 1058 P. 591 ZONED R-10 RESIDENTIAL USE

NIF GEORGE BROWN & WIFE SUSANNE C. BROWN D.B. 1176 P. 963 ZONED RA RESIDENTIAL USE

NIF BONNIE B. FREDRICK TRACT ONE D.B. 970 P. 419 ZONED RA RESIDENTIAL WOODED USE

*John L. Pierce*  
JOHN L. PIERCE, PROFESSIONAL LAND SURVEYOR NO. 2596

NIF BEAVER CREEK INVESTORS, INC. D.B. 5198 P. 941 M.B. 77 P. 235 ZONED R-10 FUTURE RESIDENTIAL

*John L. Pierce*  
JOHN L. PIERCE, PROFESSIONAL LAND SURVEYOR NO. 2596

NIF BEAVER CREEK INVESTORS, INC. D.B. 5198 P. 941 M.B. 77 P. 235 ZONED R-10 FUTURE RESIDENTIAL

*John L. Pierce*  
JOHN L. PIERCE, PROFESSIONAL LAND SURVEYOR NO. 2596

NIF JON M. HACKETT & WIFE LILA C. HACKETT D.B. 2119 P. 227 ZONED RA RESIDENTIAL USE

NIF ROBERT E. SMITH D.B. 1058 P. 591 ZONED R-10 RESIDENTIAL USE

NIF GEORGE BROWN & WIFE SUSANNE C. BROWN D.B. 1176 P. 963 ZONED RA RESIDENTIAL USE

GPS DATA: ALL COORDINATES AND BEARINGS ARE BASED ON THE NORTH AMERICAN DATUM OF 1983(2011)(epoch 2010.00). ELEVATIONS ARE BASED ON NORTH AMERICAN VERTICAL DATUM OF 1988 (NAVD88). ESTABLISHED USING NC "North Carolina GNSS Real Time Network (RTN)" ON 07-22-19

LEGEND  
TED = TOP EDGE OF DITCH  
ERRS = EXISTING RAILROAD SPIKE  
EIS = EXISTING IRON STAKE  
SIS = SET IRON STAKE  
EIP = EXISTING IRON PIPE  
SRI = SET REFERENCE IRON  
EPK = EXISTING P.K. NAIL  
SIS = SET IRON STAKE  
SPK = SET P.K. NAIL  
CP = COMPUTED POINT  
PD&UE = PUBLIC DRAINAGE & UTILITY EASEMENT  
U.E. = UTILITY EASEMENT  
C/L = CENTERLINE  
P/L = PROPERTY LINE  
MBL = MINIMUM BLDG LINE  
R/W = RIGHT-OF-WAY  
N/F = NOW OR FORMERLY  
NCSR = NORTH CAROLINA STATE ROAD  
DB = DEED BOOK  
MB = MAP BOOK  
P. = PAGE  
PP = POWER POLE  
-E- = OVERHEAD ELECTRIC LINE  
S.T. = 10' X 70' SITE TRIANGLE  
- - - = EXISTING DITCH  
- - - = STREET ADDRESS

NOTES:  
1. ALL EASEMENTS ARE 20' DRAINAGE UNLESS OTHERWISE NOTED.  
2. SIGHT DISTANCE ARE 10X70' AT INTERSECTIONS.  
3. NO WETLANDS EXIST ONSITE PER HAYWOOD PITMAN SOIL SCIENTIST ON 4-01-2020.  
4. NO PROPERTY OR BUILDINGS WITHIN OR ADJACENT TO SUBDIVISION THAT ARE LISTED IN THE NATIONAL REGISTER OF HISTORIC PLACES.  
5. ALL EASEMENTS TO BE PUBLIC AND ARE TO BE MAINTAINED BY THE HOMEOWNER'S ASSOCIATION AND NOT BY THE NC DEPARTMENT OF TRANSPORTATION.  
6. CBU WILL BE IN COMMON AREA #2.  
7. LOTS TO BE SERVED BY ONWASA SEWER AND NO SOIL SCIENTIST CERTIFICATION IS NEEDED.  
8. SECONDARY ACCESS TO BE BUILT WITH SECTION I (PER DEVELOPMENT PLANS) AND WILL BE PLATTED ON SECTION II.

TRACT DATA  
TOTAL ACREAGE = 40.07 Ac. (1,745,398.72 S.F.)  
EXISTING LOTS = 1  
PROPOSED RESIDENTIAL LOTS = 81  
AVERAGE LOT SIZE = 0.40 ACRES  
LARGEST LOT - LOT 250 (0.96 ACRES)  
SMALLEST LOT - LOT 189 (0.28 ACRES)  
OPEN SPACE AREA (TOTAL) = 12,498.85 S.F. (0.29 Ac.)  
5,630 LF OF NEW STREETS  
ZONING = R-10  
TAX PARCEL MAP NO. 54-83.4  
FIRE DISTRICT & ISO RATING = NW ONSLOW  
THIS SITE IS NOT WITHIN 1/2 MILE OF A VOLUNTARY AGRICULTURAL DISTRICT (VAD) WATERSEWER = ONWASA

SETBACK REQUIREMENTS FOR R-10:  
FRONT = 20'  
(GUM BRANCH ROAD WILL HAVE A 50' SETBACK)  
SIDE = 8'  
SIDE(S) OF CORNER LOT ABUTTING STREET = 20'  
REAR = 15'

NO PORTION OF THIS PROPERTY IS WITHIN A 100 YR. FLOOD ZONE PER FIRM 3720444-100K DATED: 6-19-2020.

Doc ID: 017014270002 Type: CRP  
Recorded: 02/21/2024 at 01:41:03 PM  
Fee Amt: \$42.00 Page 1 of 2  
Onslow County, NC  
Omega K. Jarman Reg. of Deeds  
BK 86 PG 32-33

*Omega K. Jarman*  
by *Jelena Bomke, Deputy*

REGISTER OF DEEDS

FINAL PLAT  
SHOWING  
WEDGEWOOD SECTION I  
PREPARED FOR  
BEAVER CREEK INVESTORS, INC. (OWNER)  
RICHLANDS TOWNSHIP, ONSLOW COUNTY, NC  
PREPARED BY  
JOHN L. PIERCE & ASSOCIATES, P.A.  
NORTH CAROLINA LICENSE NO. C-1888  
405 JOHNSON BLVD. JACKSONVILLE, NC 28540  
PHONE: 910-346-9800 DATE: 02-16-2024  
SCALE: 1" = 100' F.B. 1004, PG. 45  
JOB #2019-19691

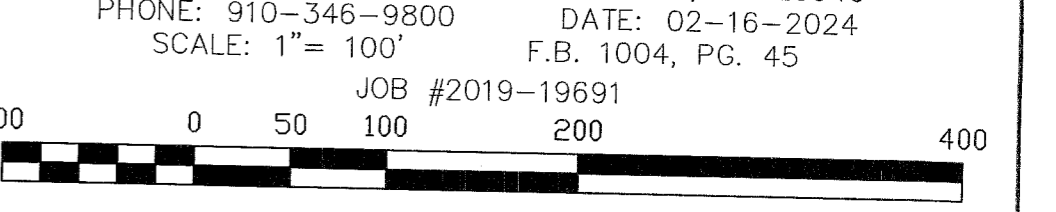

Lot No.	S.F.	Ac.	Lot No.	S.F.	Ac.
1	16144.88	0.37	211	15149.84	0.35
2	15156.33	0.35	212	14425.96	0.33
3	15156.33	0.35	213	14424.11	0.33
4	16235.75	0.37	214	14422.27	0.33
52	16261.49	0.37	215	14420.42	0.33
53	13173.17	0.30	216	28172.58	0.65
54	19946.47	0.46			
55	35883.59	0.82			
56	18103.53	0.42			
71	20275.75	0.47			
72	15817.36	0.36			
73	14974.15	0.34			
74	16197.23	0.37			
75	15432.77	0.35			
76	15978.83	0.37			
77	16484.78	0.38			
78	26269.68	0.60			
79	26808.42	0.62			
80	37143.47	0.85			
81	20512.22	0.47			
82	30482.92	0.70			
83	42511.73	0.98			
84	19288.05	0.44			
85	19468.68	0.45			
86	21541.29	0.49			
87	23164.57	0.53			
88	25259.22	0.59			
89	14088.97	0.32			
90	13974.38	0.32			
91	14049.19	0.32			
92	14059.33	0.32			
185	14283.17	0.33			
186	13576.71	0.31			
187	14360.75	0.33			
188	13634.25	0.31			
189	12300.00	0.28			
190	12300.00	0.28			
191	12442.65	0.28			
192	23193.46	0.53			
193	27996.30	0.64			
194	19838.61	0.46			
195	19938.84	0.46			
196	19559.66	0.45			
197	21167.68	0.49			
198	18511.18	0.42			
199	16766.47	0.38			
200	15745.77	0.36			
201	15971.62	0.37			
202	16303.74	0.37			
203	14621.19	0.34			
204	14888.18	0.34			
205	15646.43	0.36			
206	16634.82	0.38			
207	15960.29	0.37			
208	16443.47	0.38			
209	16771.55	0.39			
210	16465.46	0.38			

CERTIFICATE AS TO UTILITIES AND DEDICATION

I HEREBY CERTIFY THAT THE PLANS AND SPECIFICATIONS FOR THE WATER AND/OR SEWER IMPROVEMENTS FOR WEDGEWOOD SECTION I SUBDIVISION HAVE BEEN REVIEWED AND APPROVED BY ONSLOW WATER AND SEWER AUTHORITY THAT SUCH WATER AND/OR SEWER IMPROVEMENTS HAVE BEEN CONSTRUCTED, AND THAT ONSLOW WATER AND SEWER AUTHORITY HEREBY ACCEPTS THE DEDICATION OF THE WATER AND/OR SEWER IMPROVEMENTS ALONG WITH ASSOCIATED EASEMENTS. THIS 16 DAY OF Feb. 2024

*Walter M. Roy*  
 ONSLOW WATER AND SEWER AUTHORITY

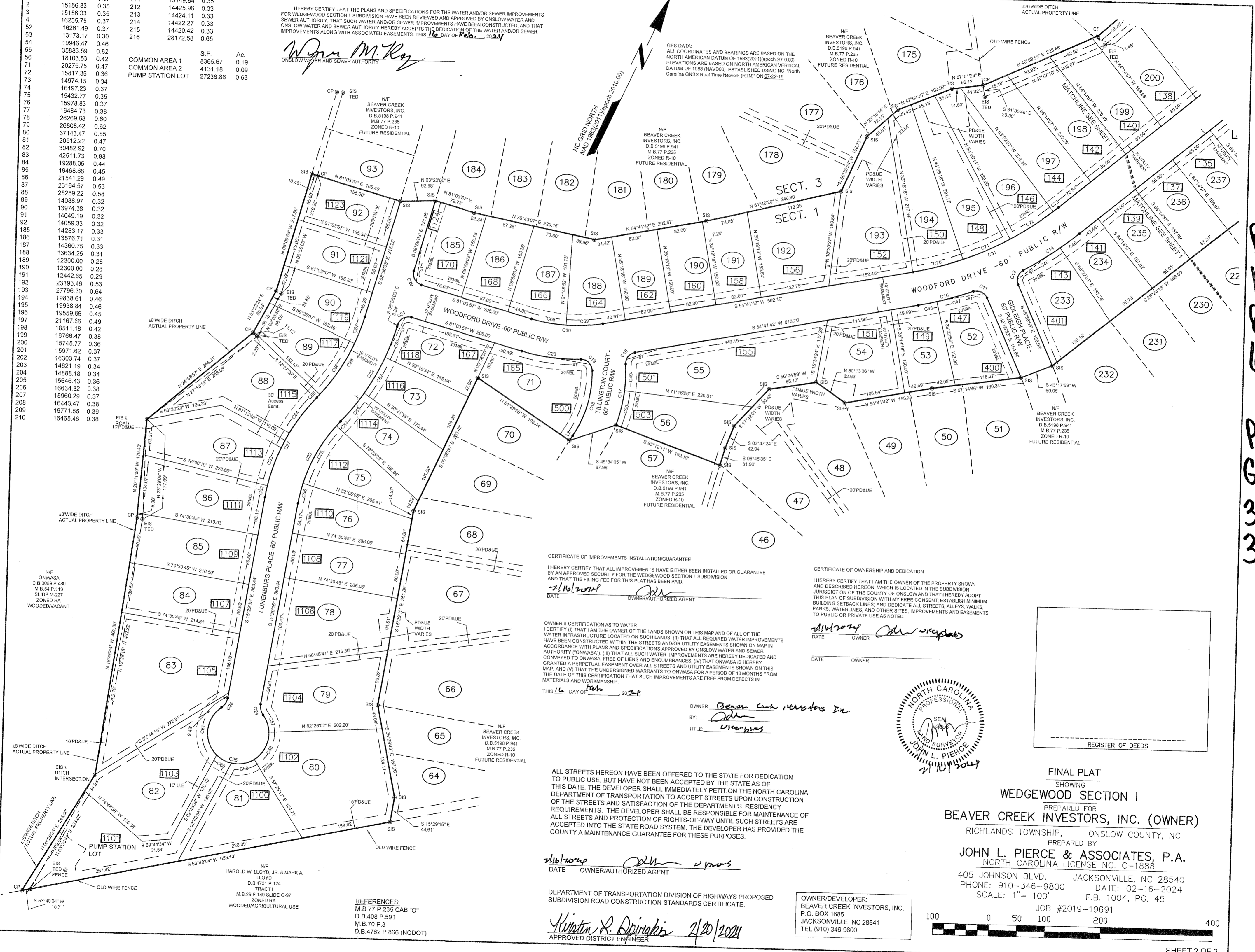

CERTIFICATE OF IMPROVEMENTS INSTALLATION/GUARANTEE

I HEREBY CERTIFY THAT ALL IMPROVEMENTS HAVE EITHER BEEN INSTALLED OR GUARANTEED BY AN APPROVED SURVEYOR FOR THE WEDGEWOOD SECTION I SUBDIVISION AND THAT THE FILING FEE FOR THIS PLAT HAS BEEN PAID.

DATE: 2/16/2024  
 OWNER/AUTHORIZED AGENT: *Benjamin C. ...*

CERTIFICATE OF OWNERSHIP AND DEDICATION

I HEREBY CERTIFY THAT I AM THE OWNER OF THE PROPERTY SHOWN AND DESCRIBED HEREON, WHICH IS LOCATED IN THE SUBDIVISION JURISDICTION OF THE COUNTY OF ONSLOW AND THAT I HEREBY ADOPT THIS PLAN OF SUBDIVISION WITH MY FREE CONSENT, ESTABLISH MINIMUM BUILDING SETBACK LINES, AND DEDICATE ALL STREETS, ALLEYS, WALKS, PARKS, WATERLINES, AND OTHER SITES, IMPROVEMENTS AND EASEMENTS TO PUBLIC OR PRIVATE USE AS NOTED.

DATE: 2/16/2024  
 OWNER: *Benjamin C. ...*

CERTIFICATE OF OWNERSHIP AND DEDICATION

I HEREBY CERTIFY THAT I AM THE OWNER OF THE LANDS SHOWN ON THIS MAP AND OF ALL OF THE WATER INFRASTRUCTURE LOCATED ON SUCH LANDS, (II) THAT ALL REQUIRED WATER IMPROVEMENTS HAVE BEEN CONSTRUCTED WITHIN THE STREETS AND/OR UTILITY EASEMENTS SHOWN ON MAP IN ACCORDANCE WITH PLANS AND SPECIFICATIONS APPROVED BY ONSLOW WATER AND SEWER AUTHORITY ("ONWASA"), (III) THAT ALL SUCH WATER IMPROVEMENTS ARE HEREBY DEDICATED AND CONVEYED TO ONWASA, FREE OF LIENS AND ENCUMBRANCES, (IV) THAT ONWASA IS HEREBY GRANTED A PERPETUAL EASEMENT OVER ALL STREETS AND UTILITY EASEMENTS SHOWN ON THIS MAP, AND (V) THAT THE UNDERSIGNED WARRANTS TO ONWASA FOR A PERIOD OF 18 MONTHS FROM THE DATE OF THIS CERTIFICATION THAT SUCH IMPROVEMENTS ARE FREE FROM DEFECTS IN MATERIALS AND WORKMANSHIP.

THIS 16 DAY OF Feb. 2024

OWNER: *Benjamin C. ...*  
 TITLE: *Owner*

ALL STREETS HEREON HAVE BEEN OFFERED TO THE STATE FOR DEDICATION TO PUBLIC USE, BUT HAVE NOT BEEN ACCEPTED BY THE STATE AS OF THIS DATE. THE DEVELOPER SHALL IMMEDIATELY PETITION THE NORTH CAROLINA DEPARTMENT OF TRANSPORTATION TO ACCEPT STREETS UPON CONSTRUCTION OF THE STREETS AND SATISFACTION OF THE DEPARTMENT'S RESIDENCY REQUIREMENTS. THE DEVELOPER SHALL BE RESPONSIBLE FOR MAINTENANCE OF ALL STREETS AND PROTECTION OF RIGHTS-OF-WAY UNTIL SUCH STREETS ARE ACCEPTED INTO THE STATE ROAD SYSTEM. THE DEVELOPER HAS PROVIDED THE COUNTY A MAINTENANCE GUARANTEE FOR THESE PURPOSES.

DATE: 2/16/2024  
 OWNER/AUTHORIZED AGENT: *Benjamin C. ...*

DEPARTMENT OF TRANSPORTATION DIVISION OF HIGHWAYS PROPOSED SUBDIVISION ROAD CONSTRUCTION STANDARDS CERTIFICATE.

*Walter R. ...* 2/20/2024  
 APPROVED DISTRICT ENGINEER

OWNER/DEVELOPER:  
 BEAVER CREEK INVESTORS, INC.  
 P.O. BOX 1685  
 JACKSONVILLE, NC 28541  
 TEL (910) 346-9800



FINAL PLAT  
 SHOWING  
 WEDGEWOOD SECTION I  
 PREPARED FOR  
 BEAVER CREEK INVESTORS, INC. (OWNER)  
 RICHLANDS TOWNSHIP, ONSLOW COUNTY, NC  
 PREPARED BY  
 JOHN L. PIERCE & ASSOCIATES, P.A.  
 NORTH CAROLINA LICENSE NO. C-1886  
 405 JOHNSON BLVD. JACKSONVILLE, NC 28540  
 PHONE: 910-346-9800 DATE: 02-16-2024  
 SCALE: 1" = 100' F.B. 1004, PG. 45  
 JOB #2019-19691

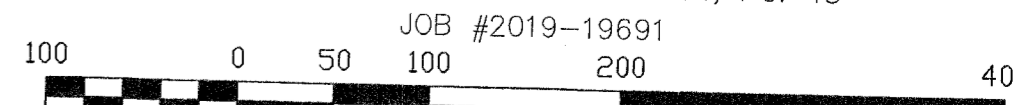

Atlantic Construction, Inc. provides a one-year structural warranty from the date of occupancy or your closing, whichever occurs first. This is an implied limited warranty; however, the following may serve as a guideline.

A. CABINETS AND COUNTERTOPS

*Doors and Drawers* – Under normal use doors and drawers should open and close properly. Doors and drawers should be even and level.

*Backsplashes*- Gaps between the cabinets/backsplashes and wall are common and result from shrinkage of materials. Caulking is a non-warrantable item.

*Grain and Stain*- By the nature of the material, some variations in wood grains and color are to be expected.

*Countertops*- There should be no significant gaps (3/16" in excess) at the seams in laminate tops. Scratches are not covered under this warranty after closing.

B. APPLIANCES

All new appliances are warranted directly by the manufacturer. Each appliance comes with a warranty card you must fill out and mail in. The warranty information will be in your homeowner package. Please read the booklets carefully and mail in all registration cards. Should any of your appliances require service, be prepared to give them your closing date, as well as the model and serial numbers of the appliance.

C. FLOORS

Both the vinyl and carpet flooring in your home have a limited manufacturer's warranty. All workmanship will be covered in your warranty. Damaged floors will not be covered after closing.

D. BATHROOMS

*Cultured marble*- DO NOT use abrasive cleaners as it may damage or scratch the surface.

*Fiberglass Tubs*- DO NOT use abrasive cleaners or strong chemical cleaners that may cause scratches or the finish to be damaged. Damaged tubs will not be repaired after closing.

E. WALLS

*Sheetrock*- Over time hairline cracks may develop at the seams. This is to be expected. Another common occurrence involves the fasteners used to attach the sheetrock to the studs. Due to the high moisture content of lumber, as studs dry out, some fasteners will back

out slightly. These can be easily repaired. The builder will repair these cracks and “*nail pops*” ONE TIME ONLY.

F. INTERIOR TRIM

*Cracks*- Separations in excess of ¼” will be corrected. As with any other natural product, grain may show through paint. Any damaged trim will not be warranted after closing.

*Maintenance*- Similar to sheetrock, trim may experience some shrinkage as it dries. You may see joints in trim work opening up or nail holes becoming visible where they were not before. Cracks in the caulk around trim are normal in the first year and is not a warrantable item.

G. WINDOWS

Windows should open and close with relative ease and operate as designed. Vinyl windows will expand when hot and shrink when cold. Sometimes you may notice they are easier to open than others. Condensation is normal due to temperature differences. Cracks or broken windows and damaged screens will not be covered after closing.

H. DOORS

*Interior*- Under normal use all interior doors should open and close freely. Damaged doors will not be covered after closing.

*Exterior*- Under normal use all exterior doors should open and close freely. Locks should also operate with reasonable ease. Damaged doors will not be covered after closing.

*Maintenance*- Inspection of exterior door thresholds and seals should be done seasonally. Any alterations needed are considered normal homeowner maintenance. It may also be necessary to clean hinges and knobs with a damp cloth once a year to prevent dust buildup.

I. HEATING AND AIR CONDITIONING

*Operation*- Under normal conditions, your A/C should be capable of maintaining a temperature of 78 degrees at five feet above the floor. In case of excessive heat a ten degree difference is acceptable. The heating system should be capable of maintaining a temperature of 70 degrees. Under extremely cold conditions a ten degree difference is acceptable. Some room temps may vary.

*Maintenance*- The manufacturer suggests changing each of your filters once per month. Any deficiencies in heating or cooling systems found to be a result of inadequate maintenance are the responsibility of the homeowner.

J. ROOF

The roof of your home has limited lifetime shingles. This warranty does not apply to storm damage or natural disasters.

K. DRIVEWAYS, PATIOS AND PORCHES

Cracks in concrete are typical due to the nature of the product. Any crack less than 1/4" is considered a non-warrantable item. Concrete driveways, patios, or sidewalks damaged after closing will not be repaired.

L. LANDSCAPING

Landscaping is not covered after closing.

M. VINYL SIDING

Cleaning of vinyl siding is the responsibility of the home owner. The best method is a pressure washer and simple green. DO NOT use Clorox.

N. PLUMBING

*Maintenance*- Inspections for leaks at drain lines and traps under sink after walk through is the responsibility of the homeowner. Any damage to cabinets will not be covered. Chlorine tablets should not be used in the toilets. Repetitive use compromises the integrity of the flapper and its components causing the toilets to continuously run requiring parts to be replaced. Use of these tablets will void any warranty.

O. SEPTIC

Do not clog your plumbing or septic lines by improperly putting the following items down your sinks or toilets: cat litter, diapers, feminine products, cigarettes, coffee grounds, grease, etc.

P. NAMED STORMS

Builder one-year warranty does not include coverage for damages caused by named storm.

Lot # \_\_\_\_\_ Subdivision \_\_\_\_\_ Buyer's Initials \_\_\_\_\_