



PARKING PAD

SQUARE FOOTAGE	
AREA	ELEV 'D3'
FIRST FLOOR	776 SQ. FT.
SECOND FLOOR	968 SQ. FT.
TOTAL (HEATING)	1744 SQ. FT.
GARAGE (UNHEATED)	260 SQ. FT.
PORCH	61 SQ. FT.
PAD	16 SQ. FT.
OPTIONAL GARAGE	240 SQ. FT.
OPTIONAL PATIO	80 SQ. FT.
OPT. COVERED PATIO	80 SQ. FT.

Total Heated -1744
Total Unheated-321

OVERALL WIDTH AND DEPTH:

STANDARD:
OPT. 1 CAR GARAGE:
OPT. COVERED PATIO:

28'-0" WIDTH BY 41'-6" DEPTH
ADD 12'-0" TO WIDTH, 0'-0" TO DEPTH
ADD 0'-0" TO WIDTH, 8'-0" TO DEPTH

28 X 41-6

ENGAGE
ELEVATION "D3"

PRICES, PROMOTIONS, INCENTIVES, FEATURES, OPTIONS, FLOOR PLANS, ELEVATIONS, DESIGNS, MATERIALS AND DIMENSIONS ARE SUBJECT TO CHANGE WITHOUT NOTICE. SQUARE FOOTAGE AND DIMENSIONS ARE ESTIMATED AND MAY VARY IN ACTUAL CONSTRUCTION. ACTUAL POSITION OF HOUSE ON LOT WILL BE DETERMINED BY THE SITE PLAN AND PLOT PLAN. FLOOR PLANS AND ELEVATION RENDERINGS ARE ARTIST CONCEPTION. FLOOR PLANS ARE THE COPYRIGHTED PROPERTY OF DREAM FINDERS HOMES. ANY USE, REPRODUCTION, ADAPTATION, OR DISPLAY OF THE PLANS IS STRICTLY PROHIBITED. SEE NEW HOME SALES CONSULTANT FOR CURRENT DETAIL. COPYRIGHT © DREAM FINDERS HOMES

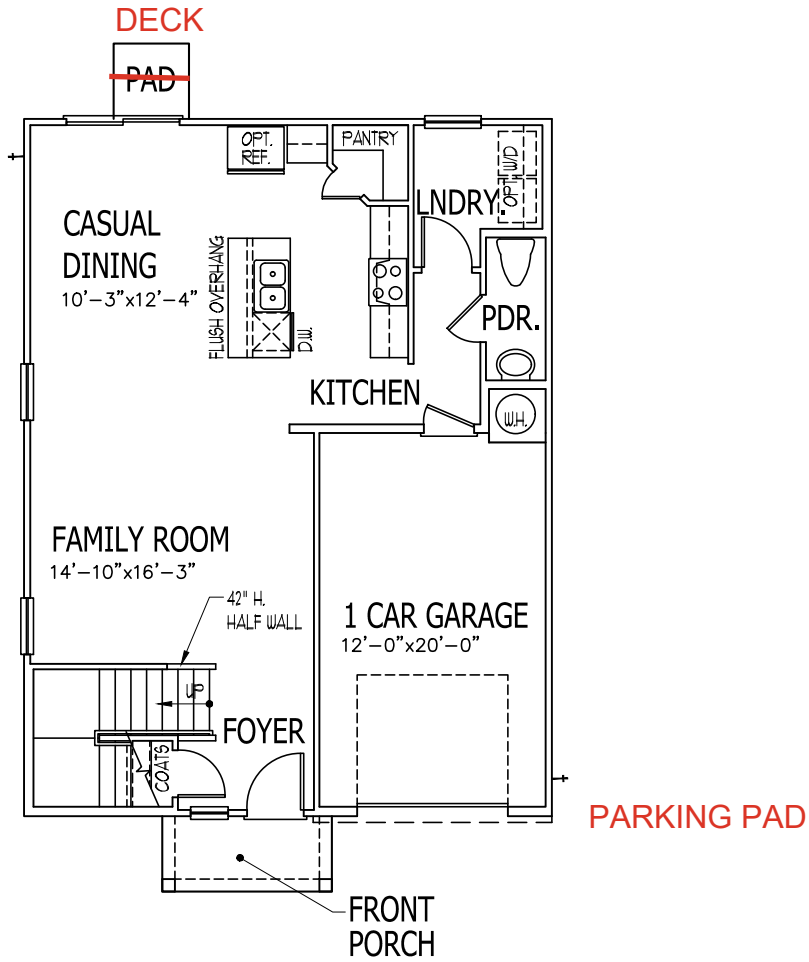

FIRST FLOOR PLAN A AND B

ENGAGE
FIRST FLOOR PLAN

A AND B

PRICES, PROMOTIONS, INCENTIVES, FEATURES, OPTIONS, FLOOR PLANS, ELEVATIONS, DESIGNS, MATERIALS AND DIMENSIONS ARE SUBJECT TO CHANGE WITHOUT NOTICE. SQUARE FOOTAGE AND DIMENSIONS ARE ESTIMATED AND MAY VARY IN ACTUAL CONSTRUCTION. ACTUAL POSITION OF HOUSE ON LOT WILL BE DETERMINED BY THE SITE PLAN AND PLOT PLAN. FLOOR PLANS AND ELEVATION RENDERINGS ARE ARTIST CONCEPTION. FLOOR PLANS ARE THE COPYRIGHTED PROPERTY OF DREAM FINDERS HOMES. ANY USE, REPRODUCTION, ADAPTATION, OR DISPLAY OF THE PLANS IS STRICTLY PROHIBITED. SEE NEW HOME SALES CONSULTANT FOR CURRENT DETAIL. COPYRIGHT © DREAM FINDERS HOMES

FD: 8-15-24



DREAM FINDERS
HOMES

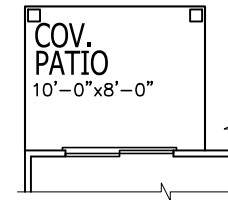

OPT. PATIO

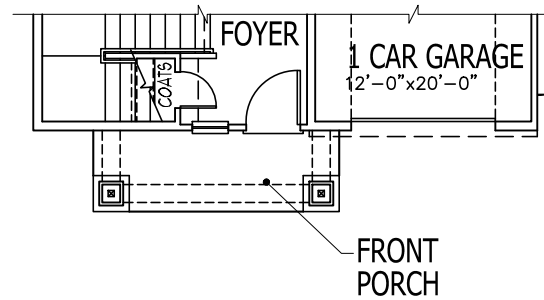

PARTIAL FIRST FLOOR PLAN D2

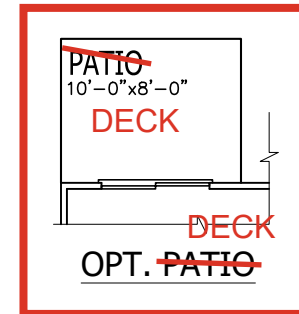

OPT. ~~PATIO~~

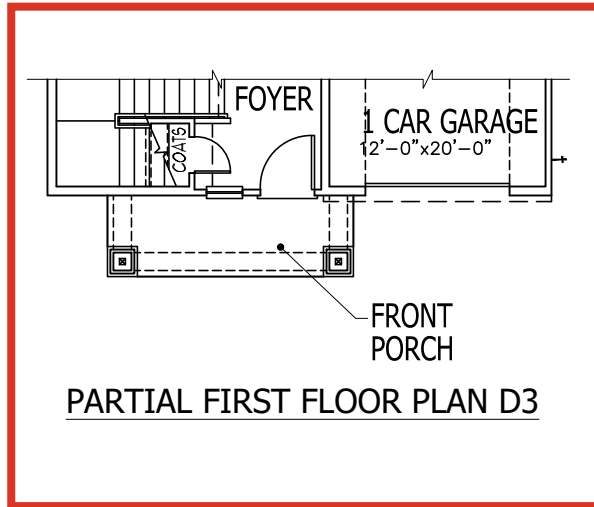

PARTIAL FIRST FLOOR PLAN D3

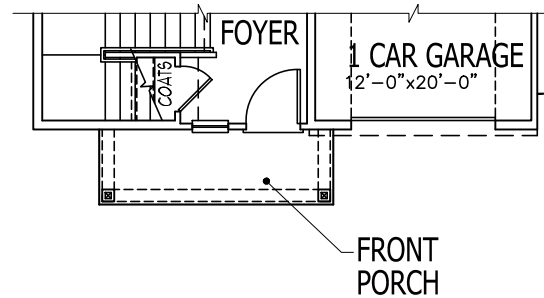

PARTIAL FIRST FLOOR PLAN D

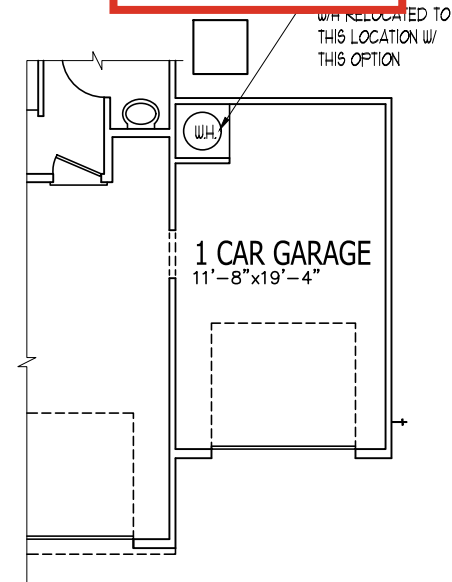

OPT. 1 CAR GARAGE

ENGAGE
FIRST FLOOR PLAN OPTIONS

PRICES, PROMOTIONS, INCENTIVES, FEATURES, OPTIONS, FLOOR PLANS, ELEVATIONS, DESIGNS, MATERIALS AND DIMENSIONS ARE SUBJECT TO CHANGE WITHOUT NOTICE. SQUARE FOOTAGE AND DIMENSIONS ARE ESTIMATED AND MAY VARY IN ACTUAL CONSTRUCTION. ACTUAL POSITION OF HOUSE ON LOT WILL BE DETERMINED BY THE SITE PLAN AND PLOT PLAN. FLOOR PLANS AND ELEVATION RENDERINGS ARE ARTIST CONCEPTION. FLOOR PLANS ARE THE COPYRIGHTED PROPERTY OF DREAM FINDERS HOMES. ANY USE, REPRODUCTION, ADAPTATION, OR DISPLAY OF THE PLANS IS STRICTLY PROHIBITED. SEE NEW HOME SALES CONSULTANT FOR CURRENT DETAIL. COPYRIGHT © DREAM FINDERS HOMES

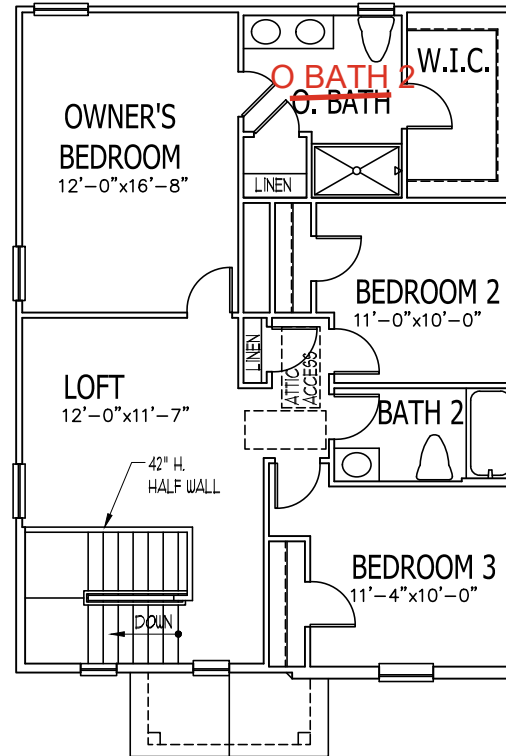

SECOND FLOOR PLAN A AND B

ENGAGE
SECOND FLOOR PLAN

PRICES, PROMOTIONS, INCENTIVES, FEATURES, OPTIONS, FLOOR PLANS, ELEVATIONS, DESIGNS, MATERIALS AND DIMENSIONS ARE SUBJECT TO CHANGE WITHOUT NOTICE. SQUARE FOOTAGE AND DIMENSIONS ARE ESTIMATED AND MAY VARY IN ACTUAL CONSTRUCTION. ACTUAL POSITION OF HOUSE ON LOT WILL BE DETERMINED BY THE SITE PLAN AND PLOT PLAN. FLOOR PLANS AND ELEVATION RENDERINGS ARE ARTIST CONCEPTION. FLOOR PLANS ARE THE COPYRIGHTED PROPERTY OF DREAM FINDERS HOMES. ANY USE, REPRODUCTION, ADAPTATION, OR DISPLAY OF THE PLANS IS STRICTLY PROHIBITED. SEE NEW HOME SALES CONSULTANT FOR CURRENT DETAIL. COPYRIGHT © DREAM FINDERS HOMES

PD: 8-15-24



DREAM FINDERS
HOMES

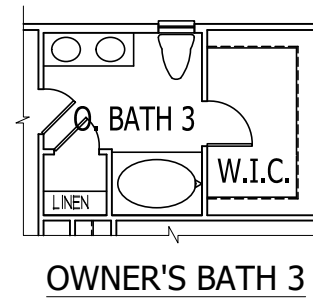
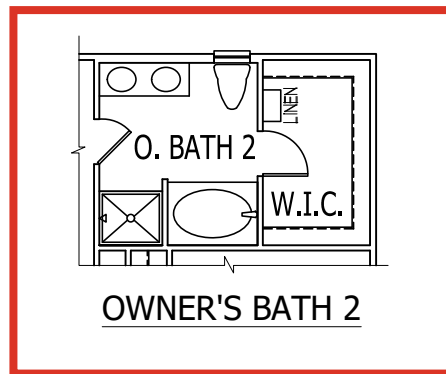

ENGAGE
SECOND FLOOR PLAN OPTIONS

PRICES, PROMOTIONS, INCENTIVES, FEATURES, OPTIONS, FLOOR PLANS, ELEVATIONS, DESIGNS, MATERIALS AND DIMENSIONS ARE SUBJECT TO CHANGE WITHOUT NOTICE. SQUARE FOOTAGE AND DIMENSIONS ARE ESTIMATED AND MAY VARY IN ACTUAL CONSTRUCTION. ACTUAL POSITION OF HOUSE ON LOT WILL BE DETERMINED BY THE SITE PLAN AND PLOT PLAN. FLOOR PLANS AND ELEVATION RENDERINGS ARE ARTIST CONCEPTION. FLOOR PLANS ARE THE COPYRIGHTED PROPERTY OF DREAM FINDERS HOMES. ANY USE, REPRODUCTION, ADAPTATION, OR DISPLAY OF THE PLANS IS STRICTLY PROHIBITED. SEE NEW HOME SALES CONSULTANT FOR CURRENT DETAIL. COPYRIGHT © DREAM FINDERS HOMES

PD: 8-15-24