

NOTE: IT IS RECOMMENDED THESE STRUCTURAL PLANS BE REVIEWED BY A STATE LICENSED STRUCTURAL ENGINEER PRIOR TO CONSTRUCTION & PERMITTING

AREA CALCULATIONS

FIRST FLOOR HEATED	1859 SF
SECOND FLOOR HEATED	777 SF
TOTAL HEATED AREA	2636 SF
GARAGE	601 SF
COVERED PORCHES	624 SF

DRAWING INDEX

A1	1st & 2nd FLOOR PLANS
A2	EXTERIOR BUILDING ELEVATIONS
A3	EXTERIOR BUILDING ELEVATIONS
A4	CROSS SECTION & CONSTRUCTION DETAILS
A5	ROOF PLAN
E1	SCHEMATIC FOUNDATION PLAN
E1	ELECTRICAL PLANS
SP	GENERAL NOTES & SPECIFICATIONS

ABBREVIATIONS

AFF	ABOVE FINISHED FLOOR
AHU	AIR HANDLING UNIT
CATH	CATHEDRAL CEILING
CLG	CONTINUOUS DIAMETER
DIA	DIAMETER
DBL	DOUBLE
DO	DOUBLE OVEN
DW	DISHWASHER
ELEV	ELEVATOR
FB	FLUSH BEAM, sized by others
FR	FRENCH GYPSUM WALL BOARD
GWB	GYPSUM WALL BOARD
HT	HEIGHT
JST	JOIST
MO	MASONRY OPENING ON CENTER
O/C	ON CENTER
PT	PRESSURE TREATED
PDS	PULL-DOWN STAIR
QTR	QUARTER
R	RISER
REF	REFRIGERATOR
RO	ROUGH OPENING
SQ	SQUARE
SHWR	SHOWER
T	TREAD
T&G	TONGUE AND GROOVE
UNO	UNLESS NOTED OTHERWISE
W/	WITH
WWM	WELDED WIRE MESH

Sullivan Design Co. does not assume any liability for the construction methods or any deviation from these plans. All information on these plans is to be verified prior to the construction of the project. Sullivan Design Co. shall not be held responsible for any errors or omissions that occur from this plan. For construction purposes, do not scale these plans. Refer to dimensions indicated on these plans. Codes govern over drawings.

Coleman Fine Homes
 406 Black Diamond Drive
 Wilmington, North Carolina

Revisions

date	description

SULLIVAN
 DESIGN COMPANY
 910 • 319 • 0210
 www.sullivancompany.com

drawn by: JLM
 date: 12/3/25
 checked by: SRS
 file name: COLEMANbelleriver2v4
 sheet number: **A1**
 copyright 2025 Sullivan Design Co. all rights reserved



2 RIGHT SIDE ELEVATION
1/4"=1'-0"

NOTE:
RUN "Z" FLASHING ABOVE ALL
HORIZONTAL APPLIED EXTERIOR TRIM
& CASINGS

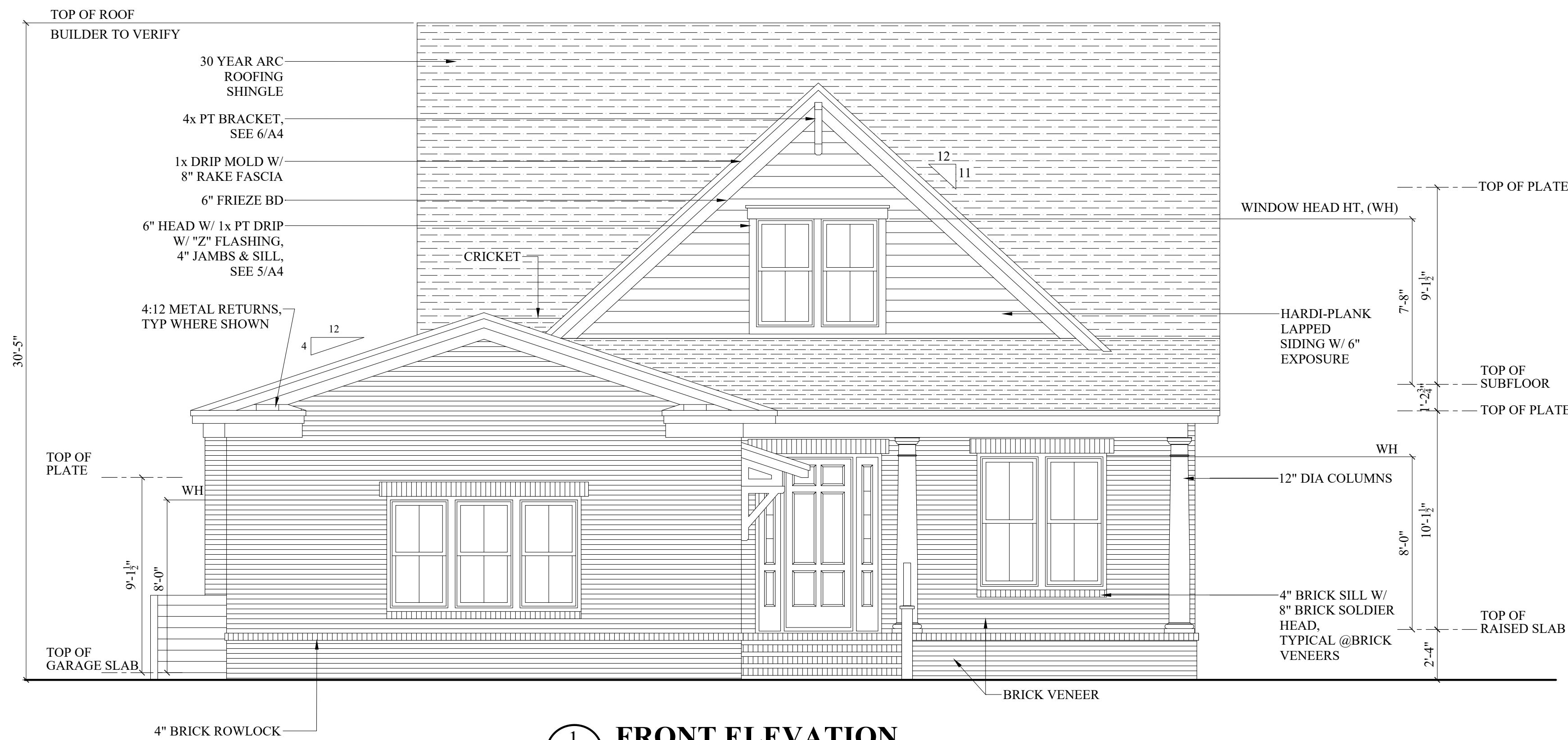

1 FRONT ELEVATION
1/4"=1'-0"

Sullivan Design Co. does not assume any liability for the construction methods or any deviation from these plans. All information on these plans is to be verified prior to the construction of the project. Sullivan Design Co. shall not be held responsible for any errors or omissions. For more information, please contact the Sullivan Design Co. prior to any deviation from this plan. For construction purposes, do not scale these plans. Refer to dimensions indicated on these plans. Codes govern over drawings.

Coleman Fine Homes

406 Black Diamond Drive
Wilmington, North Carolina

Revisions	description
date	

SULLIVAN
DESIGN COMPANY
www.sullivancompany.com
910.319.0210

drawn by: JLM

date: 12/3/25

checked by: SRS

file name:
COLEMANbelleriver2v4

sheet number:

A2

copyright 2025
Sullivan Design Co.
all rights reserved



2 LEFT SIDE ELEVATION
 A3 1/4"=1'-0"

NOTE:
 RUN "Z" FLASHING ABOVE ALL
 HORIZONTAL APPLIED EXTERIOR TRIM
 & CASINGS

NOTE:
 SEE SHEET "A2" FOR TYPICAL
 MATERIAL INFO



1 REAR ELEVATION
 A3 1/4"=1'-0"

Sullivan Design Co. does not assume any liability for the construction methods or any deviation from these plans. All information on these plans is to be verified prior to the start of construction. Sullivan Design Co. shall not be held responsible for any errors or omissions. For more information, contact the Sullivan Design Co. prior to any deviation from this plan. For construction purposes, do not scale these plans. Refer to dimensions indicated on these plans. Codes govern over drawings.

Coleman Fine Homes
 406 Black Diamond Drive
 Wilmington, North Carolina

Revisions	description
date	

SULLIVAN
 DESIGN COMPANY
 910 • 319 • 0210
 www.sullivancompany.com

drawn : by JLM

date : 12/3/25

checked by : SRS

file name :
 COLEMANbelleriver2v4

sheet number :

A3

copyright 2025
 Sullivan Design Co.
 all rights reserved

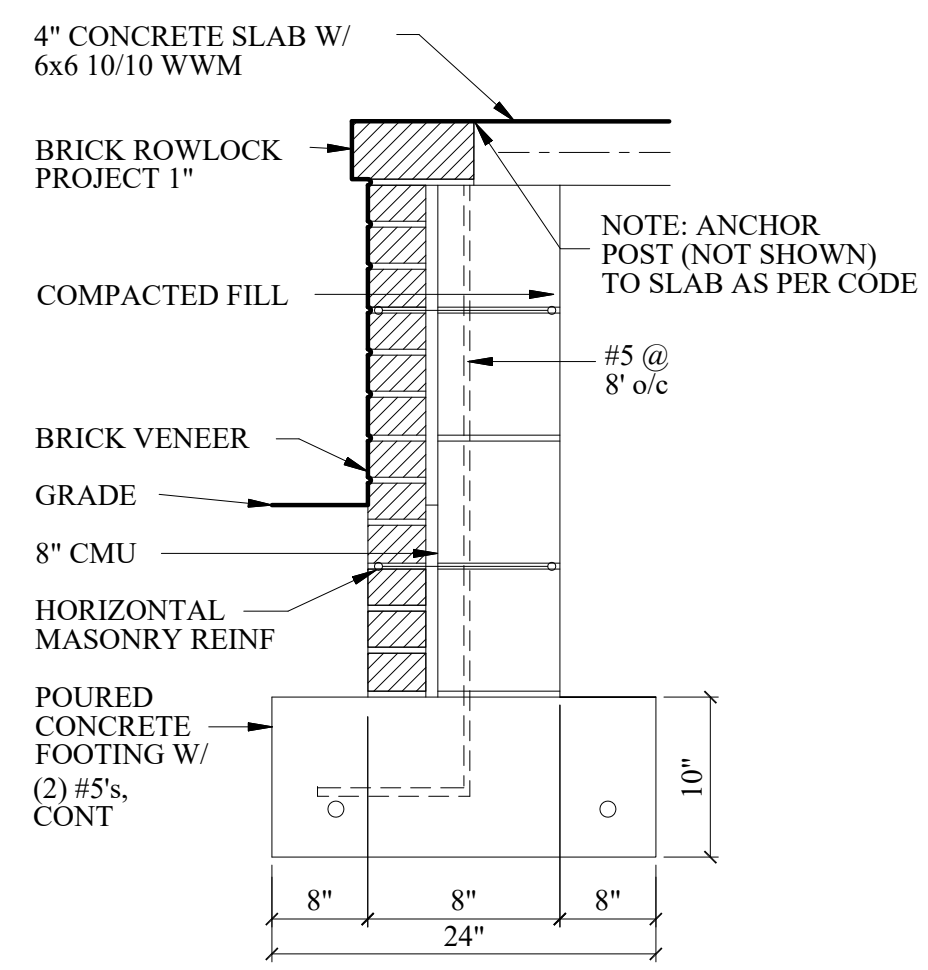

3 PORCH FOUNDATION
A4 1"=1'-0"

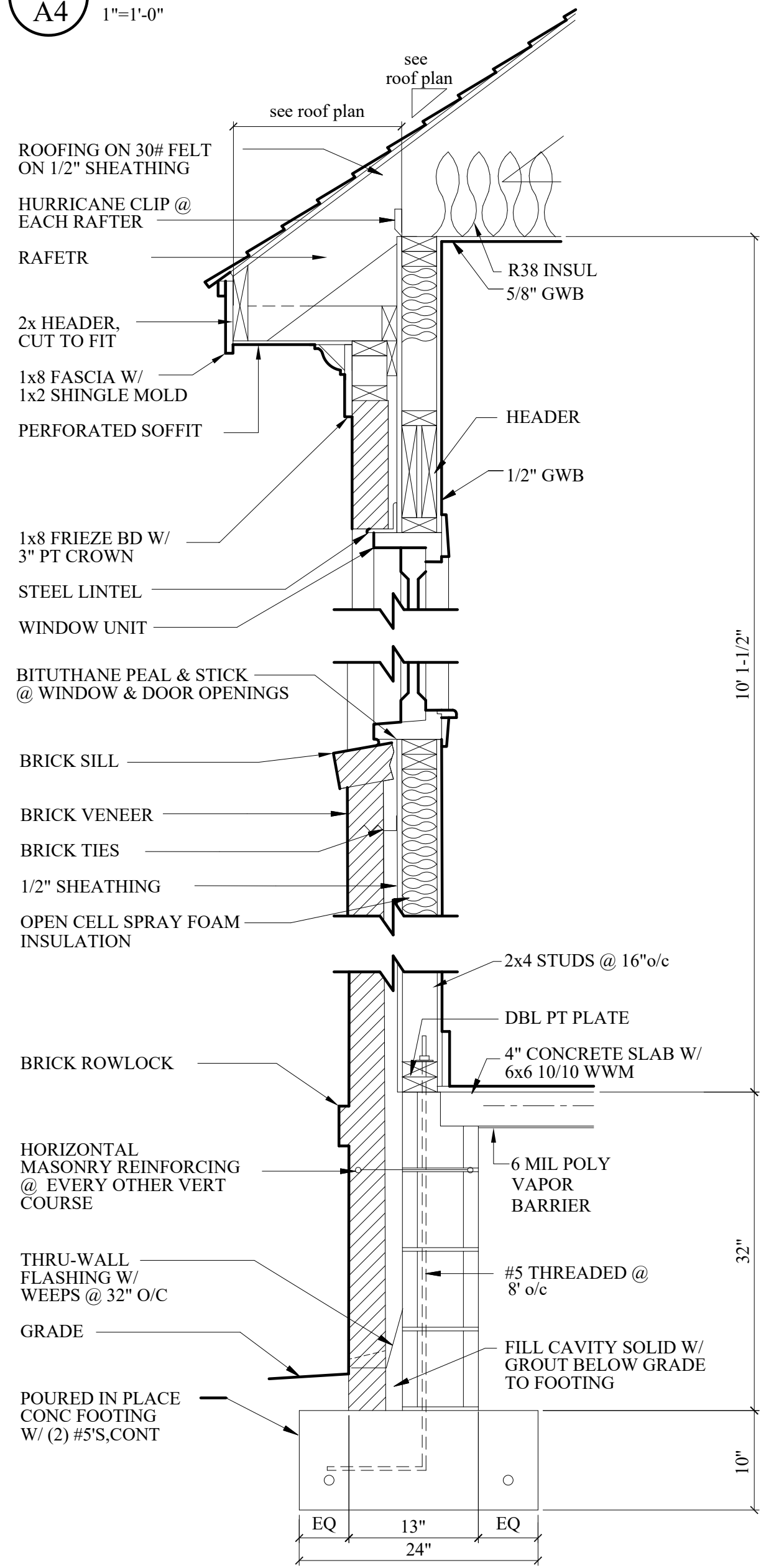

2 TYPICAL WALL SECTION
A4 1"=1'-0"

GENERAL NOTE:
CONTRACTOR IS RESPONSIBLE FOR
INSTALLING ALL PRODUCTS IN THIS
HOUSE AS PER THE MANUFACTURER'S
RECOMMENDATIONS.

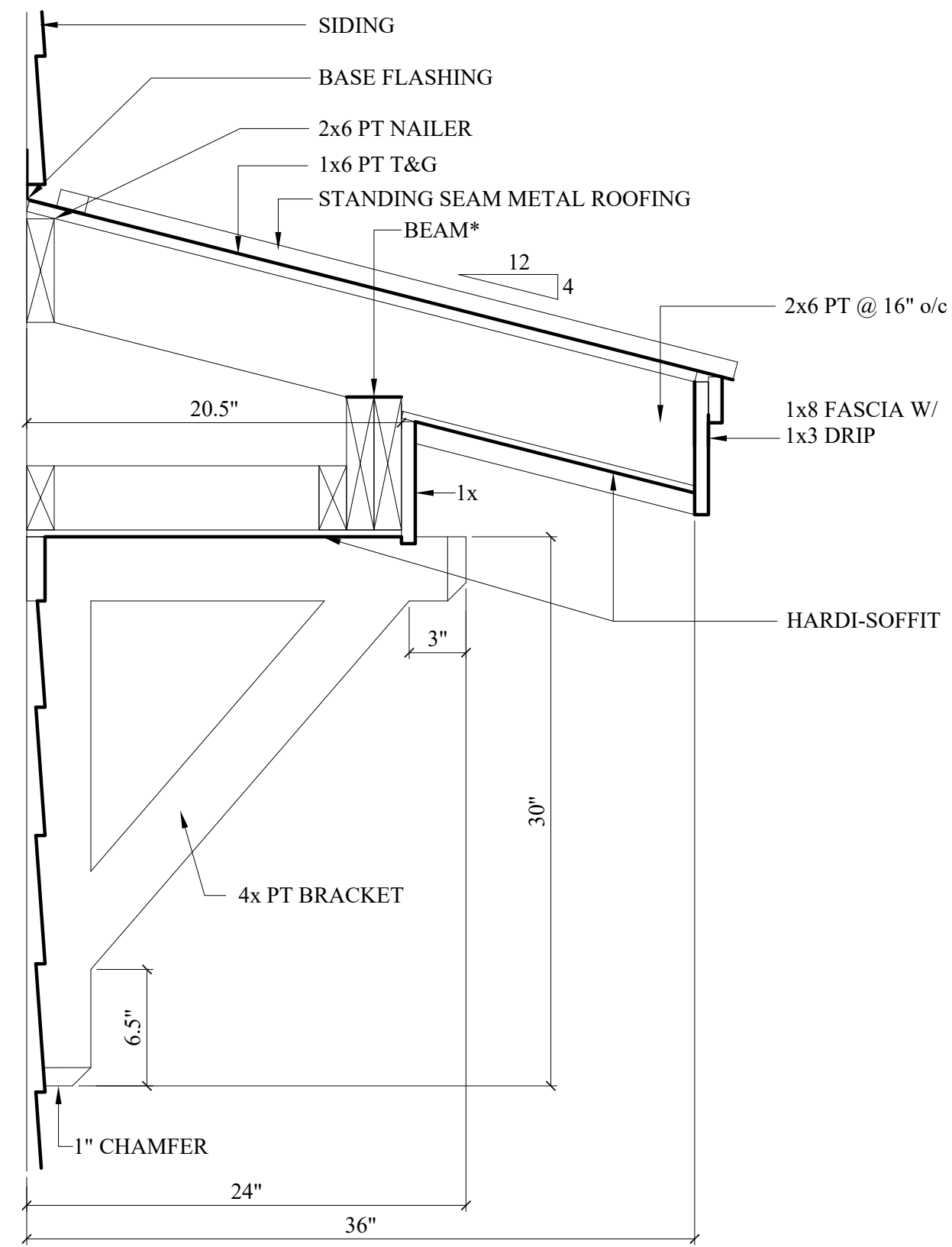

4 EYEBROW SECTION
A4 1-1/2"=1'-0"

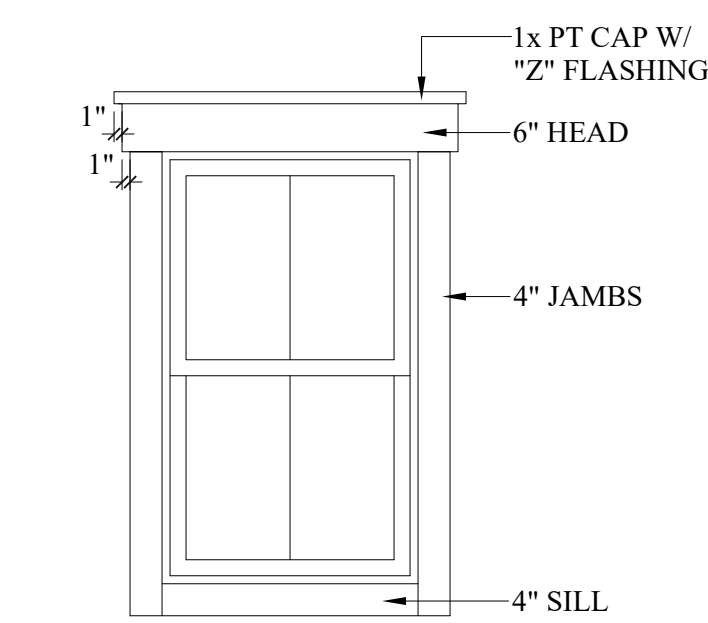

5 CASING DETAIL
A4 1/2"=1'-0"

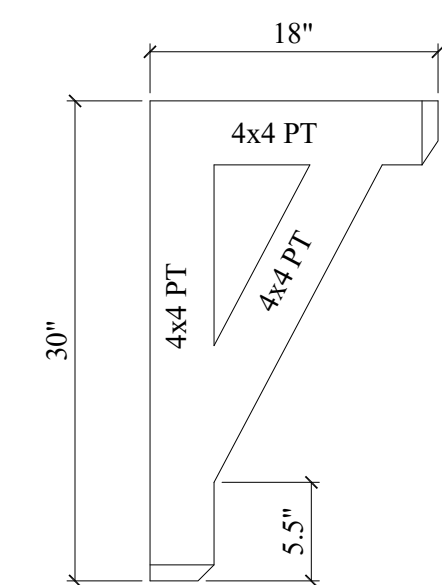

6 GABLE BRACKET DETAIL
A4 1"=1'-0"

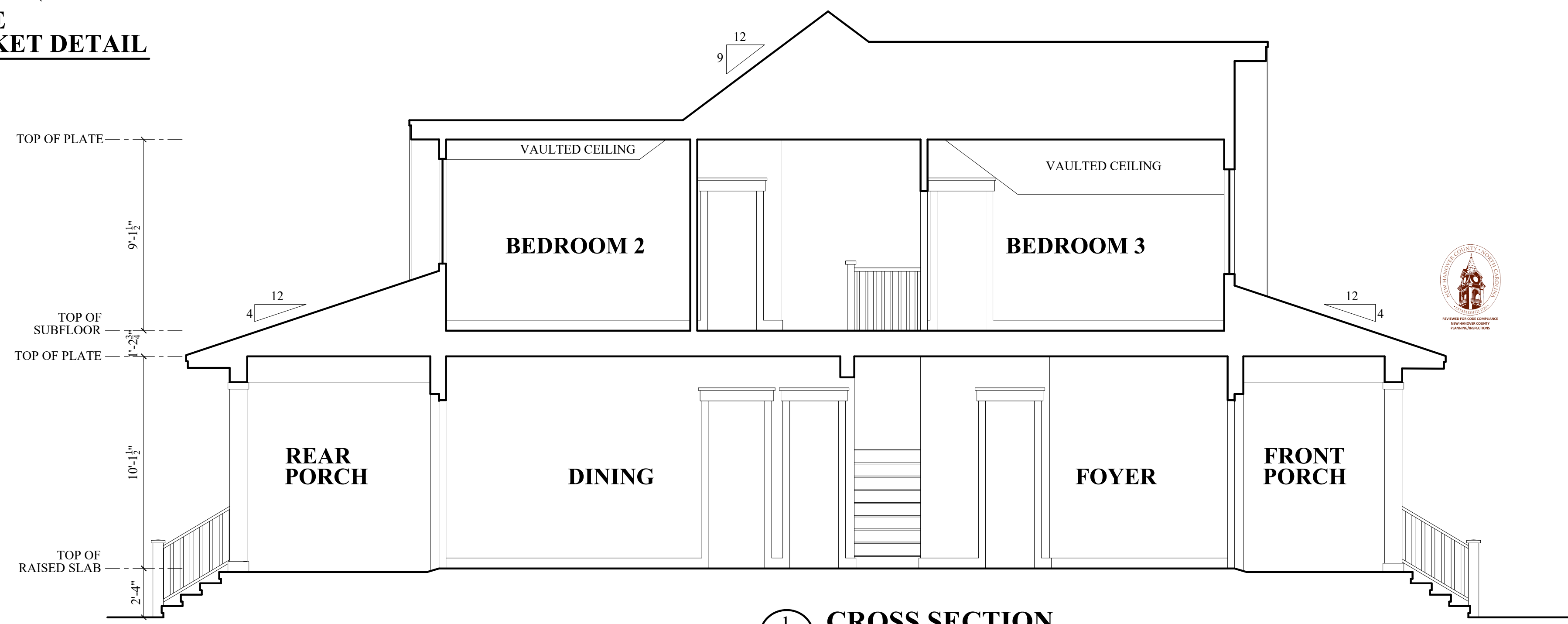

1 CROSS SECTION
A4 1/4"=1'-0"

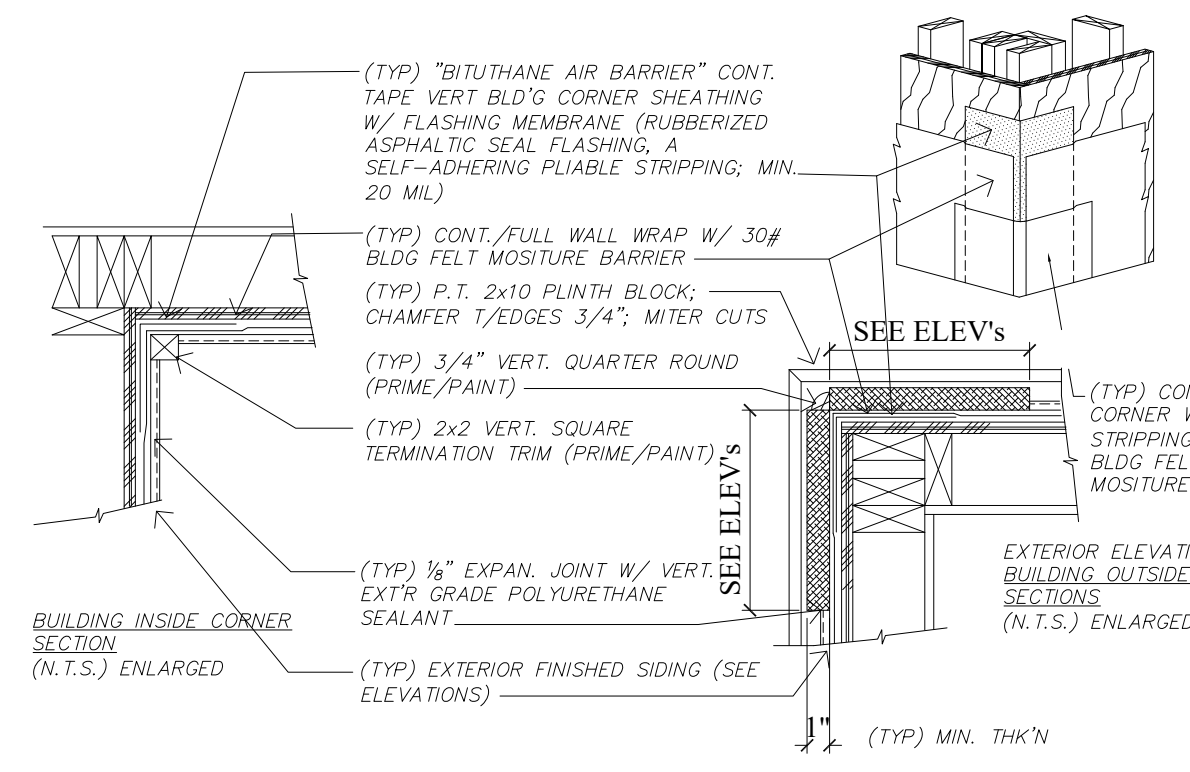

7 TYPICAL EXTERIOR CORNERS
A4 NTS

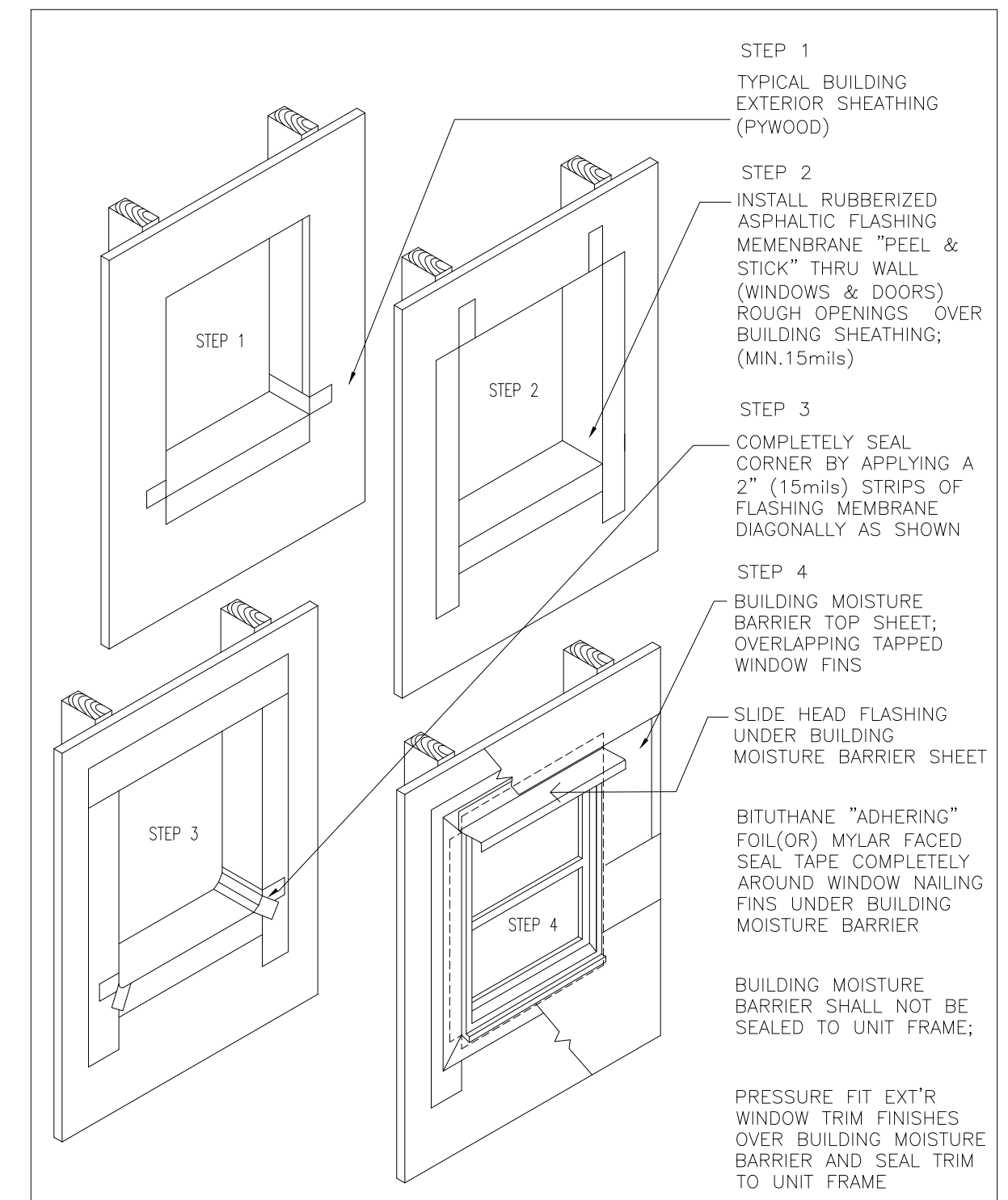

EXTERIOR WRAP AROUND PERIMETER BUILDING SHEATHING OF WINDOWS & DOORS (EXTENDING THRU ROUGH OPENING ALL FOUR EDGES) W/ MYLAR FACE FINISHED RUBBERIZED ASPHALTIC FLASHING; A SELF-ADHERING PLIABLE STRIP MEMBRANE (MIN. 15mils); MIN. 6\"/>

8 TYP WINDOW FLASHING DTL
A4 NTS

Sullivan Design Co. does not assume any liability for the construction methods or any deviation from these plans. All information on these plans is to be verified prior to the construction of the project. Sullivan Design Co. does not warrant the accuracy of these plans. For construction purposes, do not scale these plans. Refer to dimensions indicated on these plans. Codes govern over drawings.

Coleman Fine Homes
406 Black Diamond Drive
Wilmington, North Carolina

Revisions	description
date	

SULLIVAN
DESIGN COMPANY
910 • 319 • 0210
www.sullivancompany.com

drawn by: JLM
date: 12/3/25
checked by: SRS
file name: COLEMANbelleriver2v4
sheet number:

A4
copyright 2025
Sullivan Design Co.
all rights reserved

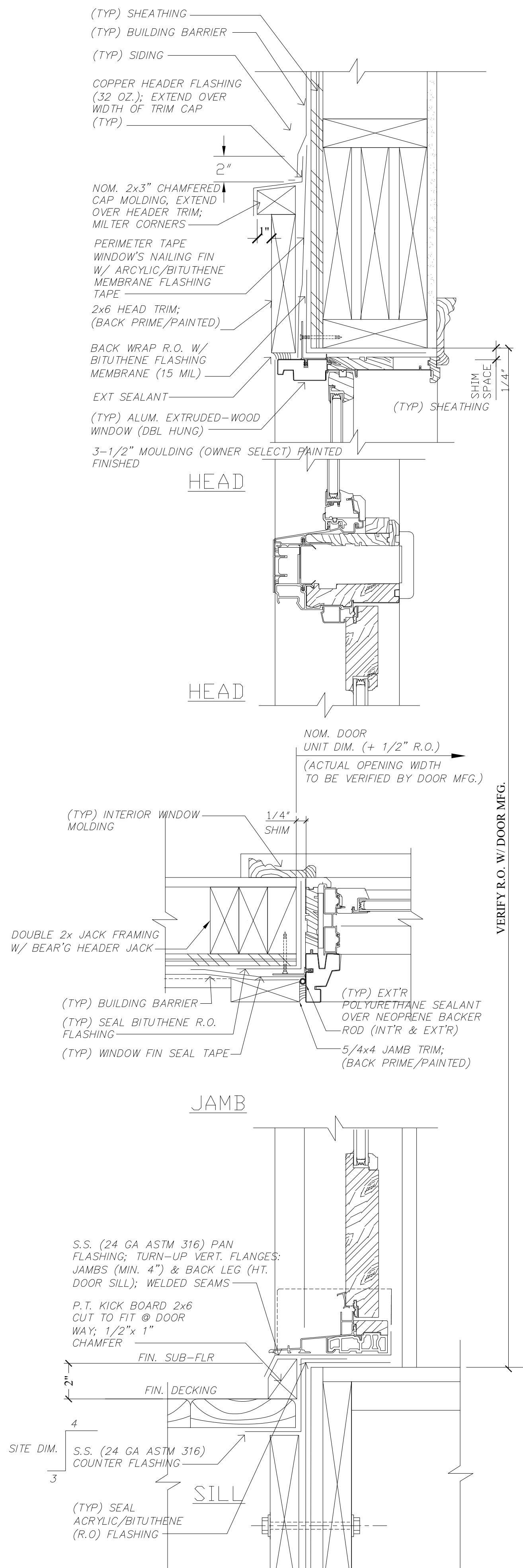

2 TYP SCHEMATIC EXT'R DOOR DTL
A5 3"=1'-0"

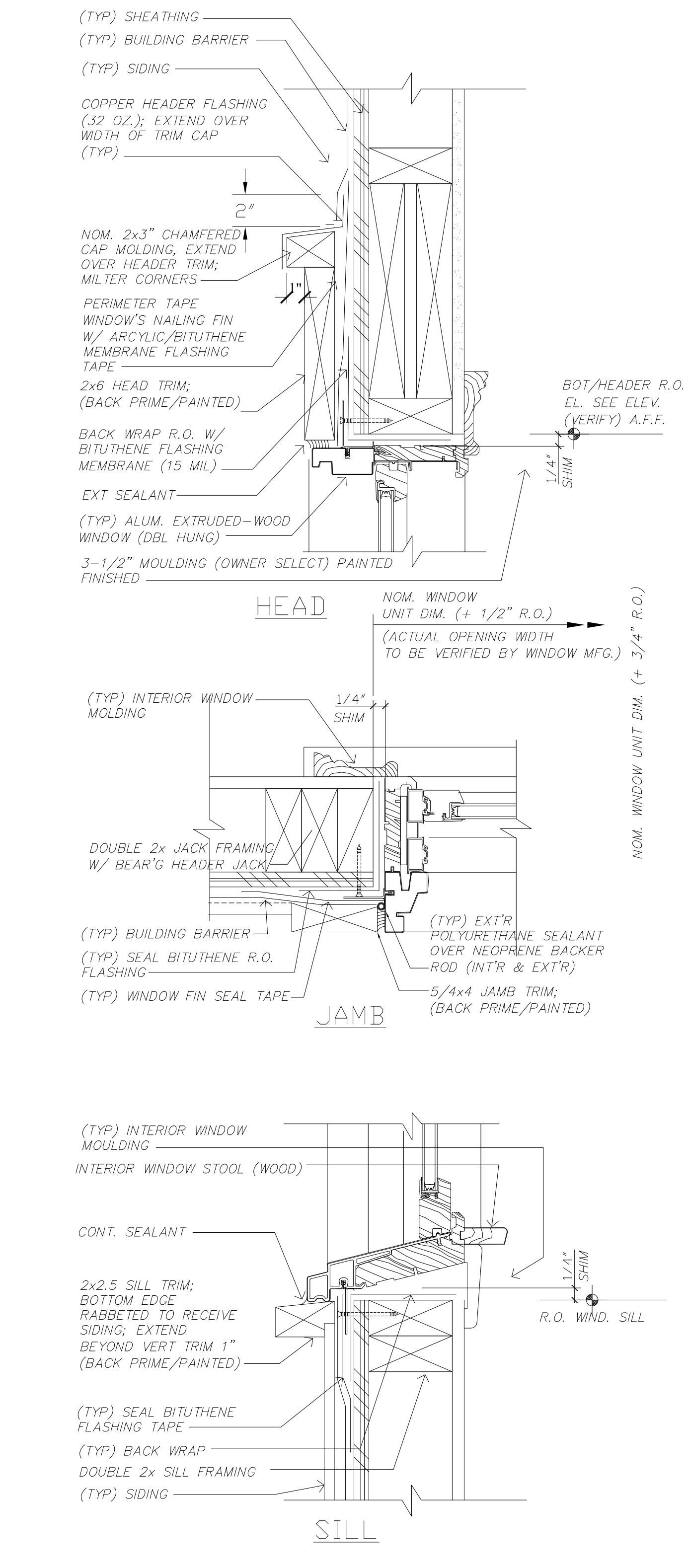

3 TYP SCHEMATIC EXT'R WINDOW DTL
A5 3"=1'-0"

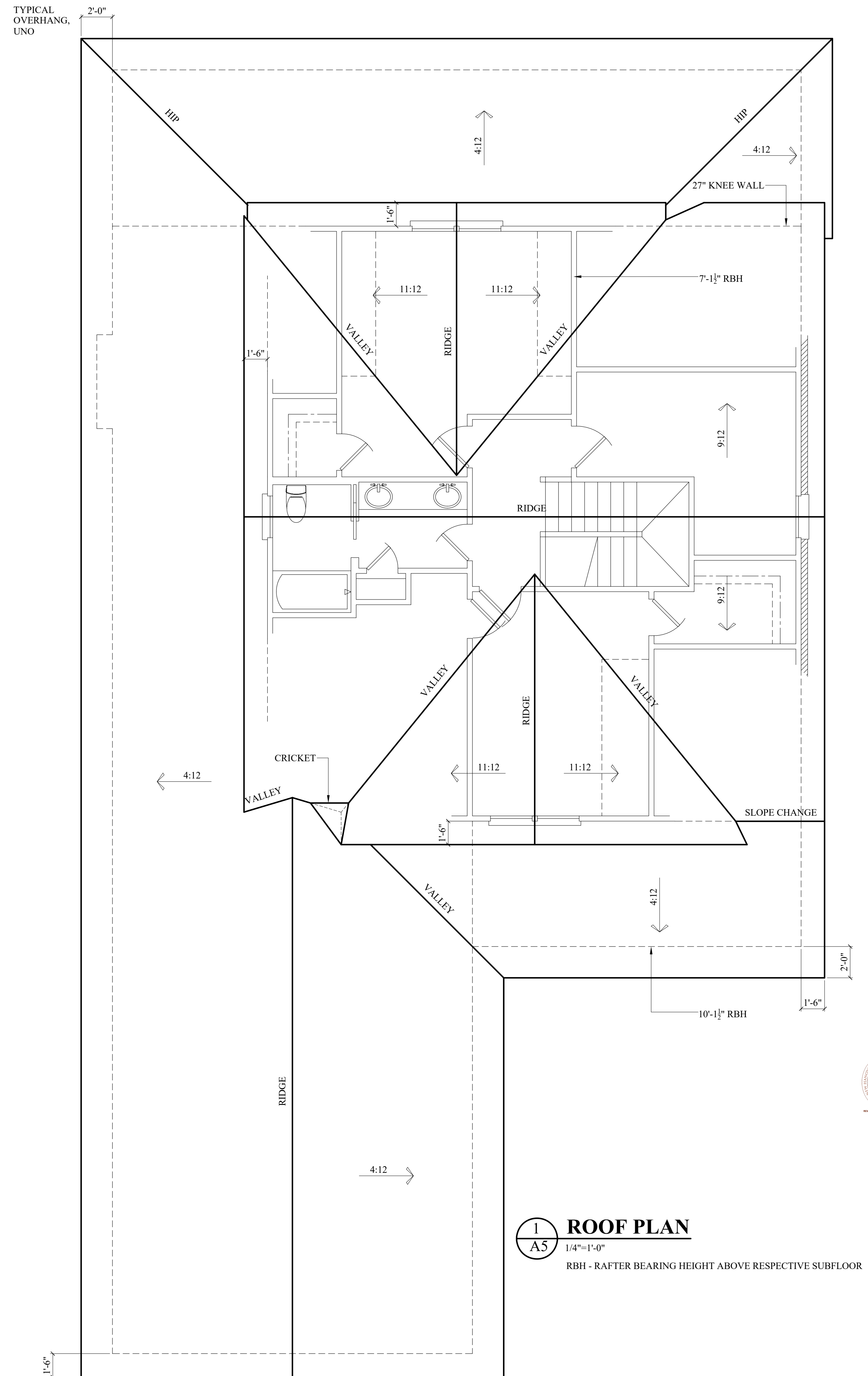

1 ROOF PLAN
A5 1/4"=1'-0"
RBH - RAFTER BEARING HEIGHT ABOVE RESPECTIVE SUBFLOOR

Sullivan Design Co. does not assume any liability for the construction methods or any deviation from these plans. All information on these plans is to be verified prior to the start of construction. Sullivan Design Co. is not responsible for any deviation from this plan. For construction purposes, do not scale these plans. Refer to dimensions indicated on these plans. Codes govern over drawings.

Coleman Fine Homes
406 Black Diamond Drive
Wilmington, North Carolina

Revisions	description
date	

SULLIVAN
DESIGN COMPANY
910 • 319 • 0210
www.sullivancompany.com

drawn by: JLM
date: 12/3/25
checked by: SRS
file name: COLEMANBelleriver2v4
sheet number:

A5
copyright 2025
Sullivan Design Co.
all rights reserved

LIMITED LICENSE FOR USE TO CONSTRUCT ONE HOME

Please read carefully. This license contains terms by which you are bound if you use this plan to construct a home. By using the plan to construct a home, you are agreeing to and accepting the terms of the license.

You are granted the right to construct one, and only one, home based on the plan. This right extends to the original purchaser of then plan only and is not transferable. You may not sell or otherwise transfer any right to copy or make use of the plan to any other party, or allow any other party to use or copy the plan.

For reproducible plans, the license includes the right to copy and modify the plan for use in the construction of the single home permitted to be constructed pursuant to the license

This plan is protected under federal copyright laws. All rights under those laws are reserved BY Sullivan Design Company. Use of the plan in a manner inconsistent with this license constitutes infringement of the copyright and a violation of U.S. copyright law.

DISCLAIMER OF WARRANTIES

SULLIVAN DESIGN COMPANY MAKES NO WARRANTIES REGARDING THE PLAN. TO THE MAXIMUM EXTENT ALLOWED BY LAW, SULLIVAN DESIGN COMPANY DISCLAIMS ALL WARRANTIES OF MERCHANTABILITY OR FITNESS FOR A PARTICULAR PURPOSE. ANY MODIFICATION OF THE PLAN VOIDS ANY AND ALL WARRANTIES EXPRESS OR IMPLIED.

LIMITATION OF LIABILITY

SULLIVAN DESIGN COMPANY WILL NOT BE LIABLE FOR ANY SPECIAL, CONSEQUENTIAL, OR INCIDENTAL DAMAGES ARISING FROM USE OF THE PLAN. TO THE EXTENT ALLOWABLE BY LAW, ANY LIABILITY OF SULLIVAN DESIGN COMPANY WILL BE LIMITED TO THE PURCHASE PRICE OF THE PLAN.

The purchaser of this plan is responsible for compliance with all local building codes and for ensuring that the plan is correctly adapted to accommodate local site conditions. The purchaser should consult with a local architect or engineer regarding these matters.

Before construction begins, the purchaser should thoroughly review this plan with the contractor, verify all dimensions, and report to Sullivan Design Company any errors, omissions or questions for clarification.

Before construction begins, the purchaser or contractor should verify all structural elements for the plan and site with a local engineer.

The exact size, reinforcement and depth of all concrete footings must be determined by local soil conditions and acceptable practices of construction. The bottom of all footings should extend below frostline. Before construction begins, the purchaser or contractor should verify the design of the footings and foundation with a local engineer.

The purchaser assumes all risks associated with adapting the plan to local sites affected by regional variations in climate, local site conditions, design needs, and building codes. Sullivan Design Company has no responsibility for adapting the plan to local site conditions, design changes, construction means or methods, costs, workmanship, quality of materials or equipment utilized in the construction.

Plans: ©2018 by Sullivan Design Company. These plans are protected under federal copyright laws. The original purchaser of these plans is authorized to build one, and only one home, as shown in the plans. Reproduction by any means, modification, or use of these plans to construct more than one home unless otherwise specifically authorized is prohibited.

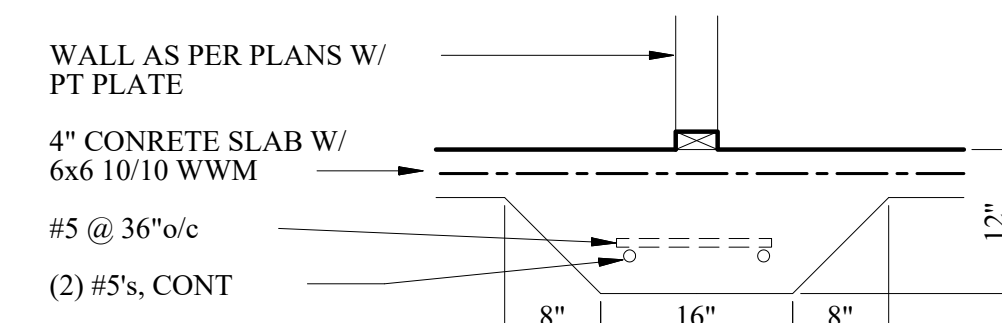
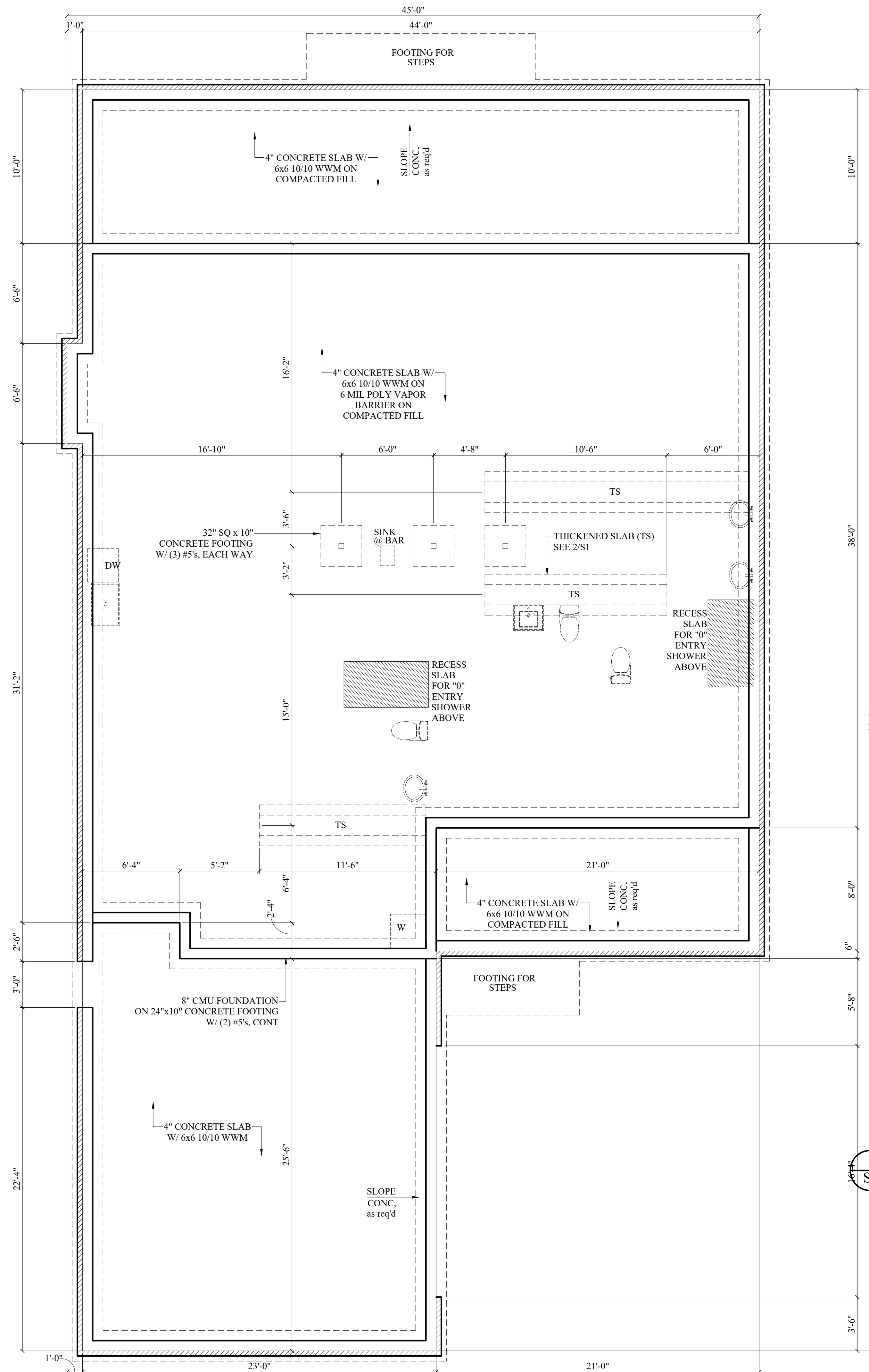

2 THICKENED SLAB
S1 NO SCALE

SCHEMATIC FOUNDATION PLAN

1/4"=1'-0"

- BRICK
- CMU

NOTE: IT IS RECOMMENDED THESE STRUCTURAL PLANS BE REVIEWED BY A STATE LICENSED STRUCTURAL ENGINEER PRIOR TO CONSTRUCTION & PERMITTING

Coleman Fine Homes

406 Black Diamond Drive
Wilmington, North Carolina

Revisions	description
date	

SULLIVAN
DESIGN COMPANY
www.sullivancompany.com
910-319-0210

drawn by: JLM
date: 12/3/25
checked by: SRS
file name: COLEMANbelleriver2v4
sheet number:

S1

copyright 2025
Sullivan Design Co.
all rights reserved

Sullivan Design Co. does not assume any liability for the construction methods or any deviation from these plans. All information on these plans is to be verified prior to the start of construction. If you have any questions, please contact the Sullivan Design Co. prior to any deviation from this plan. For construction purposes, do not scale these plans. Refer to dimensions indicated on these plans. Codes govern over drawings.

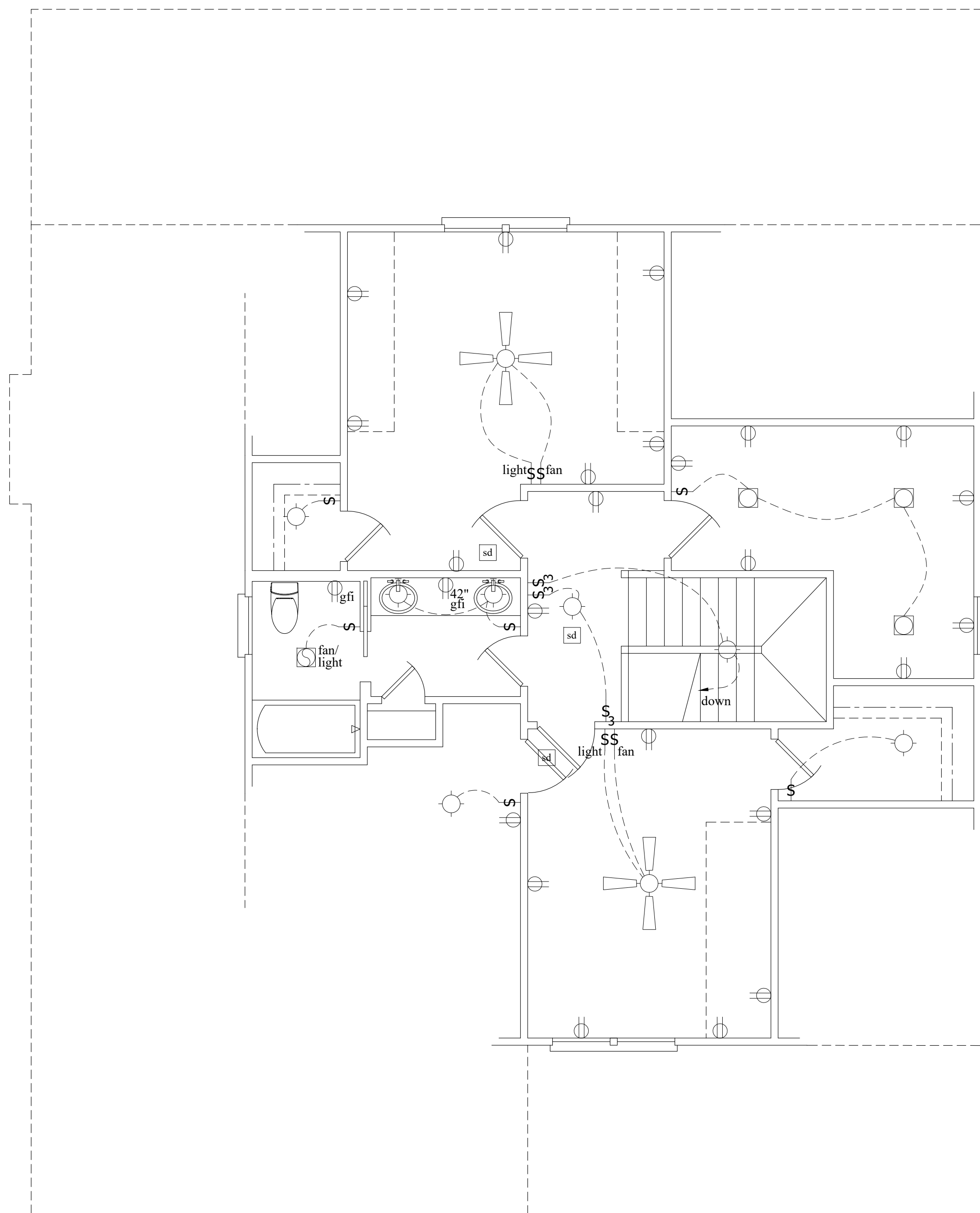
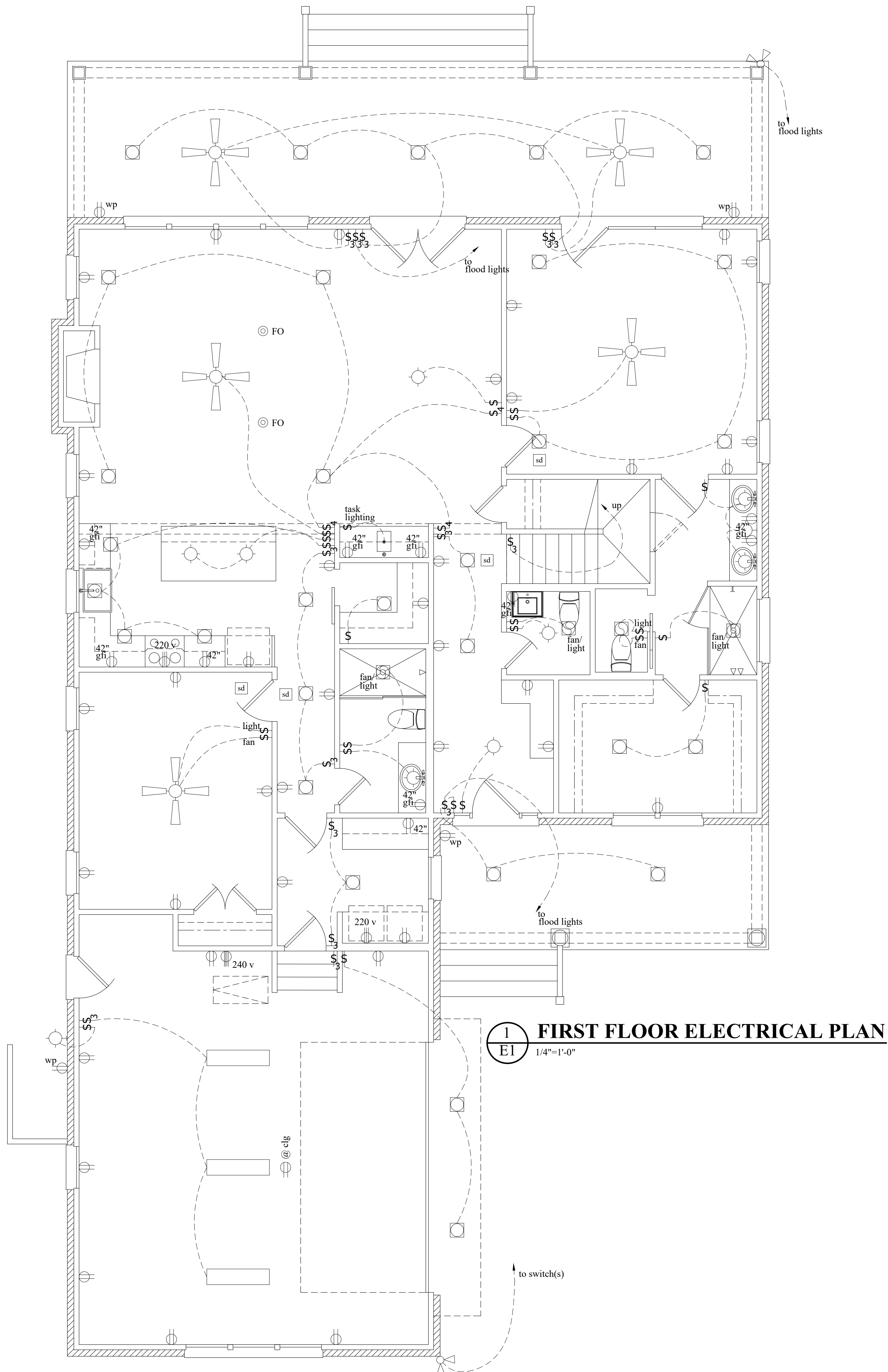

2
E1
1/4"=1'-0"
SECOND FLOOR ELECTRICAL PLAN

ELECTRICAL SYMBOL LEGEND

	DUPLEX RECEPTACLE		CEILING MOUNTED LIGHT FIXTURE
	WATERPROOF RECEPTACLE		WALL MOUNTED LIGHT FIXTURE
	GROUND FAULT INTERRUPTING RECEPTACLE		RECESSED LIGHT FIXTURE
	220 V RECEPTACLE		SHOWER LIGHT FIXTURE
	240 V RECEPTACLE		EXHAUST FAN
	DUPLEX RECEPTACLE W/ MOUNTING HEIGHT INDICATED		LIGHT/EXHAUST FAN COMBO
	SINGLE POLE SWITCH		CEILING FAN
	THREE-WAY SWITCH		*PHONE JACK
	FOUR-WAY SWITCH		*TV CABLE JACK
	RHEOSTAT SWITCH		*FLOOR OUTLET
	TIMER SWITCH		*FIBER OPTIC
	SMOKE DETECTOR		*FLOOD LIGHT
	SURFACE MOUNTED FLUORESCENT		

* LOCATED ON SITE BY OWNER



Sullivan Design Co. does not assume any liability for the construction methods or any deviation from these plans. All information on these plans is to be verified prior to the construction of the project. Sullivan Design Co. reserves the right to make changes to these plans without notice. For more information, please contact the Sullivan Design Co. prior to any deviation from this plan. For construction purposes, do not scale these plans. Refer to dimensions indicated on these plans. Codes govern over drawings.

Coleman Fine Homes
406 Black Diamond Drive
Wilmington, North Carolina

Revisions	description
date	

SULLIVAN
DESIGN COMPANY
910 • 319 • 0210
www.sullivancompany.com

drawn : by JLM
date : 12/3/25
checked by : SRS
file name : COLEMANbelleriver2v4

sheet number :
E1
copyright 2025
Sullivan Design Co.
all rights reserved

GENERAL NOTES

- THESE DRAWINGS ARE THE PROPERTY OF SULLIVAN DESIGN COMPANY (SDC) FOR USE SOLELY FOR THIS PROJECT AND SHALL NOT BE REPRODUCED, COPIED OR USED FOR OTHER PURPOSES WITHOUT WRITTEN PERMISSION OF THE SULLIVAN DESIGN COMPANY.
- THIS STRUCTURE IS ONLY STABLE IN ITS COMPLETED FORM. THE CONTRACTOR SHALL PROVIDE ALL REQUIRED TEMPORARY BRACING DURING CONSTRUCTION TO STABILIZE THE STRUCTURE.
- SDC IS NOT RESPONSIBLE FOR CONSTRUCTION SEQUENCES, METHODS, OR TECHNIQUES IN CONNECTION WITH THE CONSTRUCTION OF THIS STRUCTURE. THE SDC WILL NOT BE HELD RESPONSIBLE FOR THE CONTRACTORS FAILURE TO CONFORM TO THE CONSTRUCTION DOCUMENTS, SHOULD ANY NON-COMFORMITIES OCCUR.
- ANY STRUCTURAL ELEMENTS OR DETAILS NOT FULLY DEVELOPED ON THE CONSTRUCTION DRAWINGS BY SDC SHALL BE COMPLETED UNDER THE DIRECTION OF A STRUCTURAL ENGINEER LICENSED IN THE STATE THE STRUCTURE WILL BE CONSTRUCTED. ALL INFORMATION PROVIDED BY A STRUCTURAL ENGINEER SHALL OVERRIDE THIS PAGE.
- VERIFICATION OF ASSUMED FIELD CONDITIONS IS NOT THE RESPONSIBILITY OF SDC. THE CONTRACTOR SHALL VERIFY THE FIELD CONDITIONS FOR ACCURACY AND REPORT ANY DISCREPANCIES OR CONDITIONS THAT WOULD AFFECT CONSTRUCTION TO SDC BEFORE CONSTRUCTION BEGINS.
- THIS STRUCTURE AND ALL CONSTRUCTION SHALL CONFORM TO ALL APPLICABLE SECTIONS OF THE CURRENT INTERNATIONAL, RESIDENTIAL CODE AND ANY LOCAL LAWS WHERE THE STRUCTURE IS TO BE CONSTRUCTED. IN ALL CASES CURRENT CODES TAKE PRECEDENT OVER THE INFORMATION ON THESE HOUSE PLANS.

THE FOLLOWING SECTIONS ARE TO BE REVIEWED BY THE GENERAL CONTRACTOR FOR CONFORMANCE TO LOCAL REQUIREMENTS AND CONDITIONS PRIOR TO THE COMMENCEMENT OF PERMITTING AND CONSTRUCTION

DESIGN LOADS

MINIMUM DESIGN LOADS FOR BUILDING AND OTHER STRUCTURES, ASCE 7-10

1. ROOF LOADS	
2.1 DEAD LOAD	AS PER R301.4
2.2 LIVE LOAD	AS PER TABLE R301.6
2. FLOOR LOADING:	
3.1 ATTIC DEAD LOAD	AS PER R301.4
3.2 TYPICAL FLOOR DEAD LOAD	AS PER R301.4
3.3 LIVE LOADS	
3.3.1 ROOMS OTHER THAN SLEEPING ROOMS	40 PSF
3.3.2 SLEEPING ROOMS	30 PSF
3.3.3 STAIRS AND DECKS	40 PSF
3.3.4 BALCONIES	40 PSF

FOUNDATIONS

- THE FOUNDATION IS BASED UPON AN ASSUMED SOIL BEARING CAPACITY OF 2000 PSF NET BEARING. VERIFICATION OF THIS ASSUMED VALUE IS THE RESPONSIBILITY OF THE OWNER OR CONTRACTOR. SHOULD ANY ADVERSE SOIL CONDITION BE ENCOUNTERED A LICENSED PROFESSIONAL ENGINEER MUST BE CONTACTED BEFORE PROCEEDING.
- THE BOTTOM OF ALL FOOTINGS SHALL EXTEND BELOW THE FROST LINE FOR THE REGION IN WHICH THE STRUCTURE IS TO BE CONSTRUCTED. HOWEVER, THE TOP SHALL A MINIMUM OF 12" BELOW GRADE.
- ANY FILL SHALL BE PLACED UNDER THE DIRECTION OR RECOMMENDATION OF A LICENSED PROFESSIONAL ENGINEER. THE RESULTING SOIL SHALL BE COMPACTED TO A MINIMUM OF 95 PERCENT MAXIMUM DRY DENSITY.
- EXCAVATION FOR FOOTINGS SHALL BE LINED TEMPORARY WITH A 6 mil POLYETHYLENE IF PLACEMENT OF CONCRETE DOES NOT OCCUR WITHIN 24 HOURS OF EXCAVATION.
- NO CONCRETE SHALL BE POURED AGAINST ANY SUBGRADE CONTAINING WATER, ICE, FROST, OR LOOSE MATERIAL.

TIMBER PILES

- TIMBER PILES SHALL BE SYP MATERIAL WITH THE FOLLOWING MINIMUM DESIGN STRESS:

1.1 COMPRESSION PARALLEL TO GRAIN	1200 PSI
1.2 BENDING	2400 PSI
1.3 HORIZONTAL SHEAR	110 PSI
1.4 COMPRESSION PERPENDICULAR TO GRAIN	250 PSI
1.5 MODULUS OF ELASTICITY	1,500,000 PSI
- TIMBER PILES SHALL CONFORM TO ASTM D25
- PRESERVATIVE TREATMENT OF TIMBER PILES SHALL CONFORM TO THE REQUIREMENTS OF THE NORTH CAROLINA RESIDENTIAL CODE CHAPTER 4
- SHOULD ANY SUDDEN DECREASE IN DRIVING RESISTANCE BE ENCOUNTER CONTACT A SOILS ENGINEER BEFORE PROCEEDING.
- PILES ARE DESIGNED AS FRICTION PILES WITH AN ALLOWABLE LOAD OF 1/2 TON PER FOOT OF EMBEDMENT IN SUPPORTING STRATUM.
- ALL PILING SHALL HAVE MINIMUM TIP PENETRATION OF NOT LESS THAN 8'-0" BELOW THE NATURAL OR FINISHED GRADE WHICHEVER IS LOWER. PILING WITHIN OCEAN HAZARD AREAS SHALL HAVE A TIP PENETRATION OF AT LEAST 5'-0" BELOW MSL OR 16' BELOW AVERAGE ORIGINAL GRADE WHICHEVER IS LEAST.

CONCRETE

- CONCRETE SHALL HAVE NORMAL WEIGHT AGGREGATE AND A MINIMUM COMPRESSIVE STRENGTH (F_c) AT 28 DAYS AS LISTED BELOW.

1.1 FOOTINGS	3000 PSI
1.2 SLABS ON-GRADE	4000 PSI
1.3 ELEVATED SLABS	3500 PSI
- CONCRETE SHALL BE PROPORTIONED, MIXED, AND PLACED IN ACCORDANCE WITH ACI 318 LATEST EDITION "BUILDING CODE REQUIREMENTS FOR REINFORCED CONCRETE" AND ACI 301 LATEST EDITION "SPECIFICATIONS FOR STRUCTURAL CONCRETE FOR BUILDING"
- LIGHTWEIGHT CONCRETE SHALL HAVE A WEIGHT OF 115 PCF. (CONCRETE NOT SPECIFICALLY NOTED AS LIGHTWEIGHT SHALL BE NORMAL WEIGHT. 145 PCF)
- GROUT FOR BASE PLATES SHALL BE NON-SHRINKAGE GROUT AND HAVE A MINIMUM COMPRESSIVE STRENGTH (F_c) AT 28 DAYS OF 5000 PSI.

CONCRETE SLABS ON GRADE

- CONCRETE SLABS ON GRADE SHALL BE CONSTRUCTED IN ACCORDANCE WITH ACI 302.1R-96 "GUIDE FOR CONCRETE SLAB AND SLAB CONSTRUCTION".
- THE CONCRETE SLAB ON GRADE HAS BEEN DESIGNED USING A SUBGRADE MODULUS OF 4-250 PCI AND A DESIGN LOADING OF 200 PSF. THE SER IS NOT RESPONSIBLE FOR DIFFERENTIAL SETTLEMENT, SLAB CRACKING OR OTHER FUTURE DEFECTS RESULTING FROM UNREPORTED CONDITIONS MITIGATING THE ABOVE ASSUMPTIONS
- CONTROL JOINTS SHALL BE SPACED IN SLABS ON GRADE AT A MAXIMUM OF 20'-0" O.C. UNLESS NOTED OTHERWISE.
- CONTROL JOINTS SHALL BE PRODUCED USING CONVENTIONAL PROCESSES WITHIN 4 TO 12 HOURS AFTER THE SLAB HAS BEEN FINISHED.
- REINFORCING STEEL SHALL NOT EXTEND THROUGH THE CONTROL JOINT.
- ALL WELDED WIRE FABRIC FOR CONCRETE SLAB ON GRADE SHALL BE SUPPLIED IN FLAT SHEETS. THE WELDED WIRE FABRIC SHALL BE PLACED 2" FROM THE TOP OF SLAB AND SECURELY SUPPORTED DURING THE CONCRETE POUR.

REINFORCING STEEL

- REINFORCING BARS SHALL BE NEW BILLET STEEL CONFORMING TO ASTM A615, GRADE 60.
- DETAILING, FABRICATION, AND PLACEMENT OF REINFORCING STEEL SHALL BE IN ACCORDANCE WITH ACI 315 LATEST EDITION "MANUAL OF STANDARD PRACTICE FOR DETAILING CONCRETE STRUCTURES".
- HORIZONTAL FOOTING AND WALL REINFORCEMENT SHALL BE CONTINUOUS AND SHALL HAVE 90° BENDS OR CORNER BARS SHALL BE INSTALLED. THE CORNER BAR SHALL HAVE THE SAME SIZE AND SPACING AS THE HORIZONTAL REINFORCEMENT WITH A CLASS B TENSION SPLICE.
- LAP REINFORCEMENT AS REQUIRED A MINIMUM OF 40 BAR DIAMETERS FOR TENSION OR COMPRESSION UNLESS NOTED OTHERWISE. SPLICES IN MASONRY SHALL BE A MINIMUM OF 48 BAR DIAMETERS.
- WHERE REINFORCING DOVELLS ARE REQUIRED THEY SHALL BE EQUIVALENT SIZE AND SPACING AS THE VERTICAL REINFORCEMENT. THE DOWEL SHALL EXTEND 48 BAR DIAMETERS VERTICALLY AND 20 BAR DIAMETERS INTO FOOTING.
- WHERE REINFORCING STEEL IS REQUIRED VERTICALLY DOVELLS SHALL BE PROVIDED UNLESS NOTED OTHERWISE.

CONCRETE MASONRY

- CONCRETE MASONRY UNITS (CMU) SHALL BE ERECTED AS LOAD BEARING CONCRETE MASONRY. COMPLY WITH ACI 530.1 "SPECIFICATION FOR MASONRY STRUCTURES" FOR MATERIALS, METHODS, AND WORKMANSHIP.
- CONCRETE MASONRY UNITS SHALL CONFORM TO ASTM C90 WITH A NET COMPRESSIVE STRENGTH OF 1900 PSI.
- CMU MINIMUM COMPRESSIVE STRENGTH (F_m) SHALL BE 1500 PSI.
- MORTAR SHALL BE TYPE "M" OR "S" CONFORMING TO ASTM C270.
- ALL CELLS CONTAINING REINFORCEMENT, CELLS BELOW GRADE, AND ANY LOCATIONS NOTED ON THE PLANS SHALL BE GROUTED SOLID. GROUT SHALL HAVE A MINIMUM 28 DAY COMPRESSIVE STRENGTH (f_m) OF 2000 PSI.
- PROVIDE PREFABRICATED " LADDER-WIRE " JOINT REINFORCEMENT AT 16" O.C. VERTICALLY. REINFORCEMENT SHALL HAVE AT LEAST ONE CROSS WIRE OF AT LEAST NO. 9 GAGE STEEL FOR EACH TWO SQUARE FEET OF WALL AREA. LONGITUDINAL WIRES SHALL BE THOROUGHLY EMBEDED IN THE BED JOINT MORTAR. JOINT REINFORCEMENT SHALL BE INSTALLED IN THE FIRST TWO BED JOINTS ABOVE LINTELS AT OPENINGS. JOINT REINFORCEMENT SHALL NOT EXTEND THROUGH CONTROL JOINTS.
- BEAMS OR GIRDERS (OR POINT LOADS TRANSMITTED TO THE CMU WALL BY A COLUMN) WHICH HAVE A REACTION EXCEEDING 10 KIPS (AS NOTED ON THE DRAWINGS) SUPPORTED ON CMU WALLS SHALL HAVE A MINIMUM BEARING LENGTH OF 8 INCHES OR THE FULL WIDTH OF THE CMU WALL WHICHEVER IS LESS. THE BLOCK UNDER THE BEAM SHALL BE GROUTED SOLID FOR A DISTANCE OF THE BEARING AREA PLUS FOUR TIMES THE WALL THICKNESS. WHERE VERTICAL REINFORCING STEEL IS REQUIRED IN THE CMU WALL THE BEARING AREA SHALL HAVE A MINIMUM OF TWO REINFORCING BARS CONTINUOUS TO THE FOOTING. THESE ADDITIONAL BARS SHALL MATCH THE VERTICAL BAR SIZE.
- LOOSE STEEL ANGLES SERVING AS LINTELS FOR BRICK VENEER SHALL HAVE A MINIMUM OF 6" OF BEARING UNLESS NOTED OTHERWISE.
- PROVIDE A SOLID GROUT COURSE AT THE TOP OF THE MASONRY ELEVATIONS.

STRUCTURAL WOOD PANELS

- FABRICATION, AND PLACEMENT OF STRUCTURAL SHEATHING SHALL BE IN ACCORDANCE WITH THE APA DESIGN / CONSTRUCTION GUIDE " RESIDENTIAL AND COMMERCIAL ", AND ALL OTHER APPLICABLE APA STANDARDS.
- ALL STRUCTURALLY REQUIRED SHEATHING SHALL BEAR THE MARK OF THE APA.
- WALL SHEATHING SHALL BE APA RATED STRUCTURAL I SHEATHING. WALL SHEATHING SHALL BE ATTACHED TO ITS SUPPORTING WALL FRAMING WITH 1-84 CC NAIL AT 6" O.C. AT PANELS EDGES AND @ 12" O.C. IN PANEL FIELD UNLESS OTHERWISE NOTED ON THE PLANS. SHEATHING SHALL HAVE A SPAN RATING CONSTANT WITH THE FRAMING SPACING. APPLY BUILDING PAPER OVER THE SHEATHING AS REQUIRED.
- ROOF SHEATHING SHALL BE APA RATED SHEATHING EXPOSURE 1 OR 2. ROOF SHEATHING SHALL BE CONTINUOUS OVER TWO SUPPORTS AND ATTACHED TO ITS SUPPORTING ROOF FRAMING WITH 1-84 CC NAIL AT 6" O.C. AT PANELS EDGES AND @ 12" O.C. IN PANEL FIELD UNLESS OTHERWISE NOTED ON THE PLANS. SHEATHING SHALL BE APPLIED PERPENDICULAR TO FRAMING. SHEATHING SHALL HAVE A SPAN RATING CONSTANT WITH THE FRAMING SPACING. USE SUITABLE EDGE SUPPORT BY USE OF TAG PLYWOOD OR LUMBER BLOCKING UNLESS OTHERWISE NOTED. PANEL END JOINTS SHALL OCCUR OVER FRAMING. APPLY BUILDING PAPER OVER THE SHEATHING AS REQUIRED.
- FLOOR SHEATHING SHALL BE APA RATED SHEATHING EXPOSURE 1 OR 2. ATTACH SHEATHING TO ITS SUPPORTING FRAMING WITH 1-84 CC NAIL AT 6" O.C. AT PANELS EDGES AND @ 12" O.C. IN PANEL FIELD UNLESS OTHERWISE NOTED ON THE PLANS. SHEATHING SHALL BE APPLIED PERPENDICULAR TO FRAMING. SHEATHING SHALL HAVE A SPAN RATING CONSTANT WITH THE FRAMING SPACING. USE SUITABLE EDGE SUPPORT BY USE OF TAG PLYWOOD OR LUMBER BLOCKING UNLESS OTHERWISE NOTED. PANEL END JOINTS SHALL OCCUR OVER FRAMING. APPLY BUILDING PAPER OVER THE SHEATHING AS REQUIRED.
- SHEATHING SHALL HAVE A 1/8" GAP AT PANEL ENDS AND EDGES AS RECOMMENDED IN ACCORDANCE WITH THE APA.

TIMBER

- SOLID SAWN WOOD FRAMING SHALL CONFORM TO THE SPECIFICATIONS AS LISTED IN THE NATIONAL FOREST PRODUCTS ASSOCIATION " NATIONAL DESIGN SPECIFICATION FOR WOOD CONSTRUCTION " LATEST EDITION (NDS), THE FRAMING SHALL BE OF THE SPECIES AND GRADE AS LISTED BELOW:

1.1 JOISTS, RAFTERS, AND WOOD GIRDERS AND BEAMS	SPRUCE PINE FIR No. 2
1.2 STUDS	SPRUCE PINE FIR No. 3 OR STUD GRADE
- LVL OR PSL SHALL THE FOLLOWING MINIMUM DESIGN STRESSES:

2.1 E = 1.9 X 10 ⁶
2.2 F _b = 2600 PSI
2.3 F _v = 285 PSI
2.4 F _c = 700 PSI
- LUMBER IN CONTACT WITH CONCRETE, MASONRY, OR EARTH SHALL BE PRESSURE TREATED IN ACCORDANCE WITH AWPA STANDARD C-15. ALL OTHER EXPOSED TIMBER SHALL BE TREATED IN ACCORDANCE WITH AWPA STANDARD C-2.
- NAILS SHALL BE COMMON WIRE NAILS UNLESS OTHERWISE NOTED.
- LAG SCREWS SHALL CONFORM TO ANSI / ASME STANDARD B18.2.1-1981. LEAD HOLES FOR LAG SCREWS SHALL BE IN ACCORDANCE WITH NDS SPECIFICATIONS.
- ALL BEAM BEARING ON TIMBER FRAMING SHALL HAVE FULL BEARING FOR THE WIDTH OF THE BEAM AND SUPPORTED BY A MINIMUM OF THREE STUDS. WHERE BEAMS BEAR ONTO A WALL, PARALLEL TO THE BEAM THE BEAM SHALL HAVE A MINIMUM BEARING LENGTH OF 4'-1/2" .
- STUDS WALLS SHALL CONSIST OF 2X4 STUDS @ 16" O.C. UNLESS OTHERWISE NOTED. STUDS SHALL BE CONTINUOUS FROM THE SOLE PLATE TO THE DRB. TOP PLATE AT THE CEILING OR ROOF. STUDS SHALL ONLY BE DISCONTINUOUS AT BEAMS, HEADERS FOR WINDOW OR DOOR OPENINGS. HEADER SHALL HAVE A MINIMUM OF ONE KING STUD AT EACH END OF THE HEADER. KING STUDS SHALL BE CONTINUOUS WITH THE SAME REQUIREMENT AS STUD WALLS.
- INDIVIDUAL STUDS FORMING A COLUMN SHALL BE ATTACHED TOGETHER WITH ONE 1/4" O.C. STAGGERED. THE STUD COLUMN SHALL BE CONTINUOUS TO THE FOUNDATION OR BEAM. THE COLUMN SHALL BE PROPERLY BLOCKED AT ALL FLOOR LEVELS TO ENSURE PROPER LOAD TRANSFER.
- BEAMS CONTAINING MULTIPLE PILES OF LUMBER SHALL HAVE EACH PLY ATTACHED TO ITS ADJACENT PLY WITH 3 1/2" CC NAILS @ 12" O.C.
- FLITCH PLATE BEAMS SHALL BE ATTACHED W/ 1/2" THROUGH BOLTS AT 24" O.C. STAGGERED W/ (2) BOLTS 6" FROM EA. END.
- STEEL BEAMS SHALL BE ATTACHED TO EACH COLUMN SUPPORT WITH TWO LAG SCREWS (1/2" DIAMETER x 4" LONG). LATERAL SUPPORT IS CONSIDERED ADEQUATE PROVIDING THE JOISTS ARE TOE NAILED TO THE SOLE PLATE, AND THE SOLE PLATE IS NAILED OR BOLTED TO THE BEAM FLANGE @ 48" O.C.

STRUCTURAL STEEL

- STRUCTURAL STEEL SHALL BE FABRICATED AND ERECTED IN ACCORDANCE WITH THE AMERICAN INSTITUTE OF STEEL CONSTRUCTION " CODE OF STANDARD PRACTICE FOR STEEL BUILDINGS AND BRIDGES " AND VOLUMES 1 AND II OF THE MANUAL OF STEEL CONSTRUCTION " LOAD RESISTANCE FACTOR DESIGN " LATEST EDITION.
- STRUCTURAL STEEL SHALL RECEIVE ONE COAT OF SHOP APPLIED RUST-INHIBITIVE PAINT. STEEL WHICH IS EMBEDDED IN CONCRETE, TOP FLANGES OF BEAMS WHICH HAVE SHEAR STUDS OR STEEL THAT WILL RECEIVE SPRAY-ON FIREPROOFING SHALL NOT BE PAINTED.
- ALL STEEL SHALL HAVE THE FOLLOWING MINIMUM YIELD STRESS (F_y) LISTED BELOW:

ELEMENT	F _y (ksi)
3.1 STEEL WIDE FLANGE BEAMS AND COLUMNS	50
3.2 STEEL PIPE COLUMNS	36
3.3 TUBE STEEL	46
3.4 STEEL ANGLES AND MISC. SHAPES	36
- WELDING SHALL CONFORM TO AMERICAN WELDING SOCIETY STRUCTURAL WELDING CODE AWS D1.1 LATEST EDITION. ELECTRODES FOR SHOP AND FIELD WELDING SHALL BE CLASS E70XX. ALL WELDING SHALL BE PERFORMED BY CERTIFIED WELDERS PER THE ABOVE STANDARDS.
- ANCHOR BOLTS SHALL BE A36 STEEL UNLESS OTHERWISE NOTED.
- STEEL TO STEEL CONNECTIONS SHALL BE DESIGNED BY THE STEEL FABRICATOR FOR THE REACTIONS AS SHOWN ON THE DRAWINGS (UNFACTORED REACTIONS) USING THE STANDARD SECTIONS AND DETAILS AS SHOWN ON THESE DRAWINGS. HOWEVER ALL CONNECTIONS SHALL USE A MINIMUM OF 3/4" A-325 BOLTS AND WITH THE MINIMUM NUMBER OF BOLTS AS LISTED BELOW:

6.1 W8, W10, W12 BEAMS	2 ROWS OF BOLTS
6.2 W14, W16 BEAMS	3 ROWS OF BOLTS
6.3 W18 BEAMS	4 ROWS OF BOLTS
6.4 W21 BEAMS	5 ROWS OF BOLTS
- BOLTS SHALL BE TIGHTENED TO A SNUG TYPIC CONDITION UNO. THIS CONDITION IS ACHIEVED WHEN ALL PILES OF A CONNECTION ARE IN FIRM CONTACT. BOLTS IN TENSION, COMBINED SHEAR AND TENSION OR REQUIRED BY LRFD SPECIFICATION SECTION J1.11 MUST BE FULLY TENSIONED IN BEARING TYPE CONNECTION.
- ALL FILLET WELDS SHALL BE A MINIMUM OF -4 INCH UNLESS NOTED OTHERWISE

EXTERIOR WOOD FRAMED DECKS

- A DECK IS AN EXPOSED EXTERIOR WOOD FLOOR STRUCTURE WHICH MAY BE ATTACHED TO THE STRUCTURE OR FREESTANDING. ROOFED PORCHES MAY BE CONSTRUCTED USING THESE PROVISIONS.
- SUPPORT POSTS FOR DECKS SHALL BE SUPPORTED ON A CAST-IN-PLACE CONCRETE FOOTING. SEE CONCRETE SECTION OF THESE SPECIFICATIONS FOR CONCRETE REQUIREMENTS. THE SIZE OF THE FOOTING SHALL BE NOTED ON THE PLANS.
- LUMBER IN CONTACT WITH THE GROUND, CONCRETE OR MASONRY SHALL BE PRESSURE TREATED IN ACCORDANCE WITH AWPA STANDARD C-15. ALL REMAINING DECK LUMBER SHALL B PRESSURE TREATED IN ACCIDENCE WITH AWPA STANDARD C-2 OR A STANDARD GIVING EQUAL PROTECTION.
- WHEN ATTACHED TO A STRUCTURE, THE STRUCTURE TO WHICH ATTACHED SHALL HAVE A PRESSURE TREATED WOOD BAND FROM THE LENGTH OF THE DECK, OR METAL FLASHING SHALL BE USED TO PREVENT MOISTURE FROM COMING IN CONTACT WITH THE UNTREATED FRAMING OF THE STRUCTURE. THE DECK BAND ON THE STRUCTURE BAN SHALL BE CONSTRUCTED IN CONTACT WITH EACH OTHER EXCEPT ON BRICK VENEER STRUCTURES AND WHERE PLYWOOD SHEATHING IS REQUIRED AND PROPERLY FLASHED. SIDING SHALL NOT BE INSTALLED BETWEEN THE STRUCTURE AN THE DECK BAND. IF ATTACHED TO A BRICK VENEER STRUCTURE, NETHER FLASHING NOR A TREATED BAND FOR THE BRICK STRUCTURE IS REQUIRED. IN ADDITION, THE TREATED DECK BAND SHALL BE CONSTRUCTED IN CONTACT WITH THE BRICK VENEER.
- THE FOLLOWING SCHEDULE SHALL BE USED WHEN THE DECK IS SUPPORTED AT THE STRUCTURE BY ATTACHMENT:

ALL STRUCTURES EXCEPT BRICK VENEER STRUCTURES	
MAX. JOIST SPAN	FASTENERS
5.1 8'-0"	5/8" HDG BOLTS @ 42" O.C. AND 2-1/2 HDG NAILS @ 8" O.C.
5.2 16'-0"	5/8" HDG BOLTS @ 20" O.C. AND 3-1/2 HDG NAILS @ 6" O.C.
BRICK VENEER STRUCTURES	
MAX. JOIST SPAN	FASTENERS
5.3 8'-0"	5/8" HDG BOLTS @ 24" O.C.
5.4 16'-0"	5/8" HDG BOLTS @ 16" O.C.
5.5	NOTES: MIN. EDGE DISTANCE FOR BOLTS IS 2-1/2" MIN. NAIL PENETRATION IS 1-1/2"

THE FOLLOWING SCHEDULE SHALL BE USED FOR FLOOR DECKING. DECKING SHALL BE SYP No.2:

JOIST SPACING	DECKING
6.1 12" O.C.	1" S4S (NOMINAL)
6.2 16" O.C.	1-1/4" S4S (NOMINAL) OR 1" T&G (NOMINAL)
6.3 24" O.C.	2" S4S (NOMINAL)

SUPPORT POSTS SHALL BE SYP No.2. ALL POST HEIGHTS SHALL BE MEASURE FROM THE TOP OF THE FOOTING TO THE BOTTOM OF THE GIRDER.

POST SIZE	MAX. TRIBUTARY AREA	MAX. HEIGHT
7.1 4X4	25 SF	8'-0"
7.2 4X6	25 SF	8'-0"
7.3 6X6	25 SF	14'-0"
7.3 8X8	25 SF	20'-0"

DECKS SHALL BE BRACED TO PROVIDE LATERAL STABILITY BY ONE OF THE FOLLOWING METHODS:

- WHEN THE DECK FLOOR HEIGHT IS LESS THAN 4'-0" AND THE DECK IS ATTACHED TO THE STRUCTURE IN ACCORDANCE WITH 15.4 LATERAL BRACING IS NOT REQUIRED WHEN THE BAND AND THE FLOOR JOISTS OF THE STRUCTURE ARE PARALLEL. FULL DEPTH BLOCKING SHALL BE INSTALLED @ 24" O.C. FOR A MIN. OF ONE JOIST SPACE ON THE STRUCTURE.
- 2X6 DIAGONAL VERTICAL CROSS BRACING MAY BE PROVIDED IN TWO PERPENDICULAR DIRECTIONS TO FREESTANDING DECKS OR PARALLEL TO THE STRUCTURE AT THE EXTERIOR COLUMN LINE FOR ATTACHED DECKS. THE 2X6s SHALL BE ATTACHED TO THE POSTS WITH ONE 5/8" O HDG BOLT AT EACH BRACING MEMBER. BRACING SHALL RUN FROM THE GRADE LINE TO THE BOTTOM OF THE GIRDER.
- 4X4 WOOD KNEE BRACE MAY BE PROVIDED ON EACH COLUMN IN BOTH DIRECTIONS. THE BRACE SHALL ATTACH TO EACH POST AT A POINT NOT LESS THAN 1/3 OF THE POST LENGTH FROM THE TOP OF THE POST. THE BRACES SHALL BE ANGLES BETWEEN 45° AND 60° FROM THE HORIZONTAL. ATTACH EACH BRACE TO THE POST AND THE GIRDER WITH 1-5/8" O HDG BOLT AT EACH END. THIS TYPE OF BRACING REQUIRES A MIN. POST SIZE OF 6X6.
- POSTS MAY BE EMBEDDED IN 3000 PSI CONCRETE FOR LATERAL STABILITY AS PER THE FOLLOWING SCHEDULE:

POST SIZE	MAX. TRIBUTARY AREA	MAX. HEIGHT ABOVE TOP OF FTG.	EMBEDDED DEPTH	CONCRETE DIAMETER	
8.1 8.1	6X6	25 SF	6'-0"	3'-6"	1'-8"
8.2	8X8	25 SF	10'-0"	4'-6"	2'-0"
8.3	8X8	25 SF	12'-0"	5'-4"	2'-0"

WOOD TRUSSES

- THE WOOD TRUSS MANUFACTURER / FABRICATOR IS RESPONSIBLE FOR THE DESIGN OF THE WOOD TRUSSES. SUBMIT SEALED SHOP DRAWINGS AND SUPPORTING CALCULATION TO THE CONTRACTOR FOR REVIEW PRIOR TO FABRICATION. THE CONTRACTOR SHALL HAVE A MINIMUM OF FIVE (5) DAYS FOR REVIEW. THE REVIEW BY THE CONTRACTOR SHALL BE FOR OVERALL COMPLIANCE WITH THE DESIGN DOCUMENTS. THE CONTRACTOR SHALL ASSUME NO RESPONSIBILITY FOR THE CORRECTNESS FOR THE STRUCTURAL DESIGN FOR THE WOOD TRUSSES.
- THE WOOD TRUSSES SHALL BE DESIGNED FOR ALL REQUIRED LOADINGS AS SPECIFIED IN THE NORTH CAROLINA RESIDENTIAL CODE, THE ASCE STANDARD "MINIMUM DESIGN LOADS FOR BUILDING AND OTHER STRUCTURES" (ASCE 7-98), AND THE LOADING REQUIREMENT SHOWN ON THESE SPECIFICATIONS. THE TRUSS DRAWINGS SHALL BE COORDINATED WITH ALL OTHER CONSTRUCTION DOCUMENT AND PROVISIONS PROVIDED FOR LOADS SHOWN ON THESE DRAWINGS INCLUDING BUT NOT LIMITED TO HVAC EQUIPMENT, PIPING, AND ARCHITECTURAL FIXTURES ATTACHED TO THE TRUSSES.
- THE TRUSSES SHALL BE DESIGNED, FABRICATED, AND ERECTED IN ACCORDANCE WITH THE "NATIONAL DESIGN SPECIFICATION FOR WOOD CONSTRUCTION" (NDS) LATEST EDITION AND THE LATEST EDITION OF THE "DESIGN SPECIFICATION FOR METAL PLATE CONNECTED WOOD TRUSSES".
- THE TRUSS MANUFACTURER SHALL PROVIDE ADEQUATE BRACING INFORMATION IN ACCORDANCE WITH "COMMENTARY AND RECOMMENDATIONS FOR HANDLING, INSTALLING, AND BRACING METAL PLATE CONNECTED WOOD TRUSSES (HB-9)". THIS BRACING, BOTH TEMPORARY AND PERMANENT, SHALL BE SHOWN ON THE SHOP DRAWINGS. ALSO, THE SHOP DRAWINGS SHALL SHOW THE REQUIRED ATTACHMENTS TO THE TRUSSES.
- SUPPORT SHALL BE PROVIDED FOR ALL NON-LOAD BEARING PARTITIONS PARALLEL TO THE TRUSSES. THIS SUPPORT SHALL EITHER BE ACHIEVED BY INSTALLING AN EXTRA TRUSS UNDER THE PARTITION OR BY PROVIDING 2X BLOCKING ATTACHED TO EACH ADJACENT TRUSS WITH A JOIST HANGER. EITHER METHOD MAY BE USED, HOWEVER THIS DESIGN IS THE RESPONSIBILITY OF THE TRUSS MANUFACTURER AND SHALL BE PROVIDED EVEN IF THE PARTITIONS ARE NOT SPECIFICALLY NOTED ON THE PROPOSED TRUSS LAYOUT.
- ANY CHORDS OR TRUSS WEBS SHOWN ON THESE DRAWINGS HAVE BEEN SHOWN AS A REFERENCE ONLY. THE FINAL DESIGN OF THE TRUSSES SHALL BE PER THE MANUFACTURER.

Sullivan Design Co. does not assume any liability for the construction methods or any deviation from these plans. All information on these plans is to be verified prior to the construction of the project. Should there occur any deviation from the Sullivan Design Co. plans, prior to any deviation from this plan, for construction purposes, do not scale these plans. Refer to dimensions indicated on these plans. Codes govern over drawings.

Coleman Fine Homes
 406 Black Diamond Drive
 Wilmington, North Carolina

Revisions	
date	description

SULLIVAN
 DESIGN COMPANY
 910 • 319 • 0210
 www.sullivancompany.com



drawn : by JLM

date : 12/3/25

checked by : SRS

file name : COLEMANbellinger2v4

sheet number :

SP
 copyright 2025
 Sullivan Design Co.
 all rights reserved